

Europe force



HSC

Hochgeschwindigkeits-
Fräser

Torusfräser

VHM - Fräser High - Speed

Hard - Cutter
- 70 HRC

XNF - High - Speed - Fräser

VHM Fräser

High Speed ALU

HRC 65







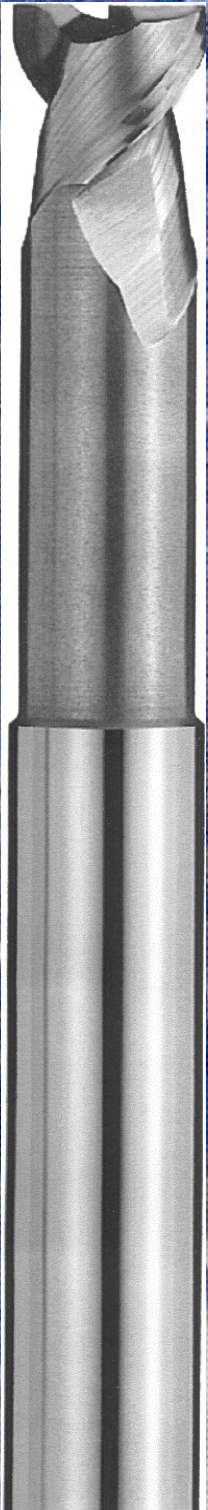

















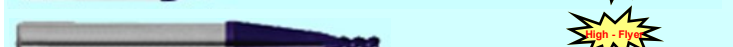

HPC

HSC

Hard Cutting

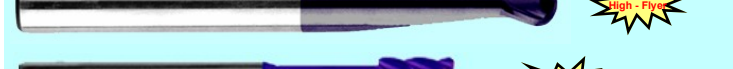



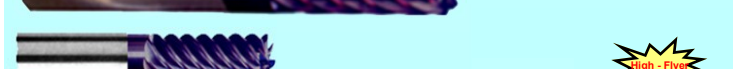









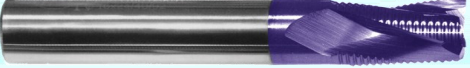
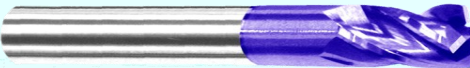









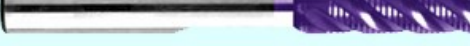



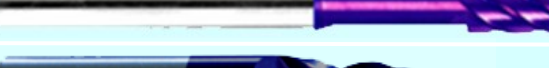



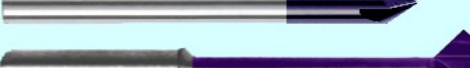









	ALU-VHM-Bohrnutenfräser mit Eckenradius+abgesetztem Schaft		3/3 + 3/4
	ALU-VHM-Bohrnutenfräser abgesetztem Schaft		3/3
	ALU-VHM-Schaftfräser mit Eckenradius+abgesetztem Schaft	extra lang	3/5
	ALU-VHM-Schlichtfräser		3/7
	ALU-VHM-Radiusfräser		3/6
	ALU-VHM-Radiusfräser abgesetztem Schaft	extra lang	3/6
	ALU-VHM-Schrupfräser		3/8
	ALU-VHM-Einzahnfräser	für ALU	3/9
	DIAMOND-beschichteter VHM-Fräser		3/12
	DIAMOND-beschichteter VHM-Fräser lange Ausführung		3/12
	X-V-10-VHM-Fräser HPC ungleiche Zahnteil- + Drallwinkelsteigung		3/11
	VHM-MICRO-Fräser		3/13
	VHM-MICRO-Fräser	lang	3/14
	VHM-MICRO-Fräser mit Radius	lang	3/15
	VHM-Mini-3-Schneiden-Fräser	kurz	3/16
	VHM-Mini-3-Schneiden-Fräser	lang	3/17
	VHM-Schaftfräser	kurz + lang	3/18
	VHM-Schaftfräser		3/19
	VHM-Schlichtfräser	kurz + lang	3/20 + 3/21
	VHM-Schlichtfräser	extra lang	3/22
	VHM-Radiusfräser	HSC	3/23 + 3/24
	VHM-Radiusfräser HighSpeed + HRC60	lang	3/25
	VHM-Kugelkopffräser High Speed + HRC60		3/26 + 3/27
	VHM-Torusfräser HardCutting + HRC65		3/27
	VHM-Cutter Hartfräser	HRC65	
	VHM-Schlichtfräser	lang	3/28
	VHM-Schlichtfräser	HSC kurz	3/29
	VHM-Schlichtfräser	mit abgesetztem Schaft	3/29

VHM-Fräser

Übersicht

VHM-Fräser

Übersicht

		VHM-Schaftfräser	HighSpeed HSC	lang	Seite 3/30
		VHM-Schrupfräser			3/31
		VHM-Schlicht- + Schrupfräser mit Eckradius ungleiche Zahnteilung + verschiedene Drallwinkel			3/32
		VHM-Hochvorschubfräser	HPC		3/32
		VHM-Schrupfräser	HPC		3/33
		VHM-Schrupfräser	HPC + HighSpeed		3/33
		VHM-Feinschrupfräser			3/34
		VHM-Feinschrupfräser	HPC + HighSpeed Mit Innenkühlung		3/34
		VHM-Feinschrupfräser	HPC	kurz	3/35
		VHM-Feinschrupfräser	HPC	lang	3/35
		VHM-Schaftfräser X-TREME		lang Mit Eckenradius	3/36
		VHM-Torusfräser mit Eckradius		lang	3/37
		VHM-Gesenkräser		konisch	3/38 + 3/39
		VHM-Entgrater + Fasenfräser			3/40
		VHM-Vor- und Rückwärtsentgrater			3/41
		VHM-Radius -Vor- und Rückwärtsentgrater			3/41
		VHM-Schlitzfräser		kreuzverzahnt	3/42
		VHM-Winkelfräser		45° / 60°	3/43
		VHM-Viertelkreisfräser			3/44
		VHM-NC-Anbohrer	90° 120° 142°		3/45
		VHM-Senker			3/46
		VHM-Stichel		30° 60° 90°	3/46
		VHM-Rundstäbe	MICRO GRAIN ULTRA FINE		3/47 3/47

VHM ALU-Bohrnutenfräser

HSC

4000

4000 B

4000 W

4000 WB

EXTREM - SPEED - ALU beschichtet

EXTREM - SPEED - ALU beschichtet

Europe
force

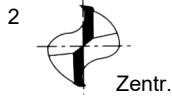

Typ
W

- Eintauchen und Längsfräsen für sämtliche ALU- und NE-Metalle sowie Kunststoffe und Kupfer.
- Geeignet zum Hochgeschwindigkeitsfräsen.
- Höchstleistung mit neuer VHM - Ultra Fine - Fräser für Aluminium.
- Extra lange Ausführung mit Eckenradius und abgesetztem Schaft.
- Auch universell einsetzbar.

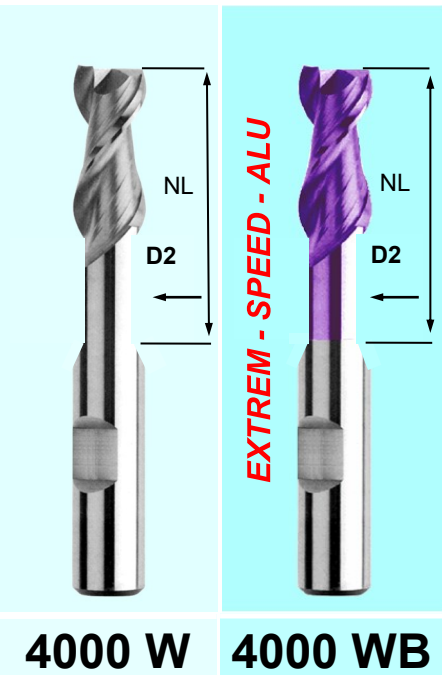
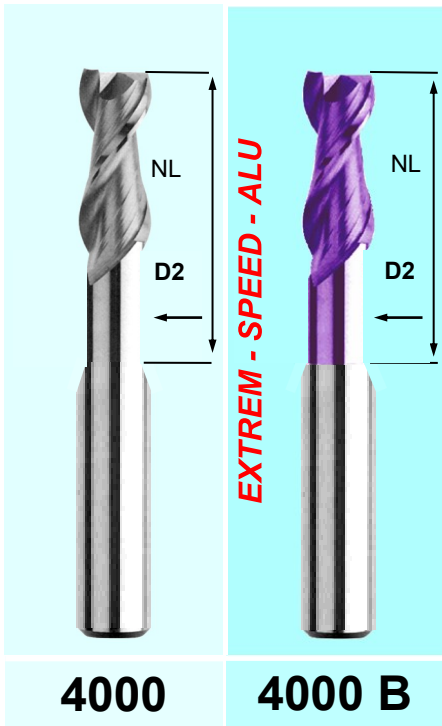

							4000 4000W	4000 B 4000 WB			
Thermo Plast. Alu	Alu Guss > 10% Si	Stahl < 750N	Stahl < 900N	Stahl < 1400N	Stahl < 55HRC	INOX	Ti + Cu	GG (G)	Uni- versal		
Ø e ₈	Ecken- Radius	Schneid- länge	Ø D2 NL = Nutzlänge	Schaft- Ø	Ges.- länge	Z	 4000 4000W		 4000 B 4000WB		
..0300	3.0		7.0	2.8 x 14	3.0	38	2	14.30	18.70		
..0350	3.5		7.0	3.2 x 14	6.0	57	2	25.30	30.80		
..0400	4.0		8.0	3.7 x 18	6	57	2	20.90	25.30		
..0450	4.5		8.0	4.2 x 18	6	57	2	25.30	30.80		
..0500	5.0		10.0	4.6 x 20	6	57	2	25.30	31.90		
..0600	6.0		10.0	5.5 x 22	6	57	2	25.30	31.90		
..0800	8.0		16.0	7.4 x 28	8	63	2	23.10	30.80		
..01000	10.0		19.0	9.2 x 32	10	72	2	37.40	52.80		
..1200	12.0		22.0	11.0 x 38	12	83	2	50.60	69.30		
..1400	14.0		22.0	13.0 x 40	14	83	2	73.70	93.50		
..1600	16.0		26.0	15.0 x 44	16	92	2	95.70	118.80		
..2000	20.0		32.0	19.0 x 54	20	104	2	159.50	203.50		

Best.-Nr.
4000...
4000B...
4000W...
4000WB...

VHM ALU-Bohrnutenfräser mit Eckradius

HSC

4002

4002 B

EXTREM - SPEED - ALU beschichtet

Europe
force

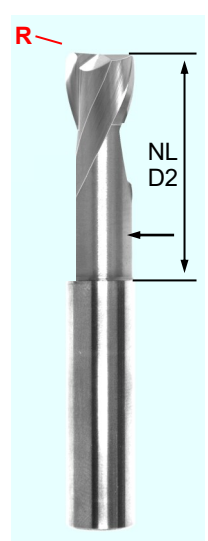
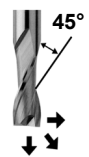
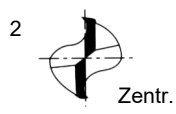

4002

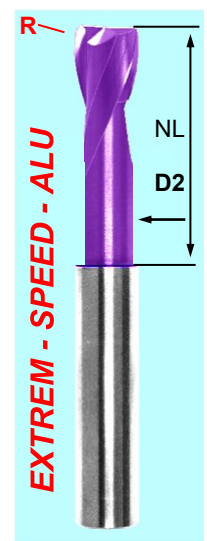

4002 B

Typ
W

- Eintauchen und Längsfräsen für sämtliche ALU- und NE-Metalle sowie Kunststoffe und Kupfer.
- Geeignet zum Hochgeschwindigkeitsfräsen.
- Höchstleistung mit neuer VHM - Ultra Fine - Fräser für Aluminium.
- Extra lange Ausführung mit Eckenradius und abgesetztem Schaft.
- Auch universell einsetzbar.



Best.-Nr. 4000... 4000B... 4000w... 4000wb... 4002... 4002B...	Thermo Plast. Alu	Alu Guss > 10% Si	Stahl < 750N	Stahl < 900N	Stahl < 1400N	Stahl < 55HRC	INOX	Ti + Cu	GG (G)	Uni-versal	4002	4002 B
	Ø e ₈	Ecken-Radius	Schneid-länge	Ø D2 NL = Nutzlänge	Schaft-Ø	Ges.-länge	Z				4002	4002 B
..020005	2	0.5	3.0	1.8 x 9	6	55	2				37.40	46.20
..030005	3	0.5	4.0	2.8 x 16	6	55	2				37.40	46.20
..040005	4	0.5	5.0	3.7 x 16	6	55	2				37.40	46.20
..060005	6	0.5	7	5.5 x 20	6	60	2				37.40	49.50
..060010	6	1.0	7	5.5 x 20	6	60	2				37.40	49.50
..080005	8	0.5	9	7.4 x 25	8	60	2				47.30	56.10
..080010	8	1.0	9	7.4 x 25	8	60	2				47.30	56.10
..0100005	10	0.5	11	11.0 x 32	10	70	2				70.40	84.70
..1000010	10	1.0	11	11.0 x 32	10	70	2				70.40	84.70
..120005	12	0.5	12	12.0 x 38	12	80	2				94.60	118.80
..120010	12	1.0	12	12.0 x 38	12	80	2				94.60	118.80

4001

4001 B

4001 W

4001 WB

EXTREM - SPEED - ALU beschichtet

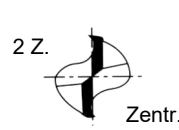
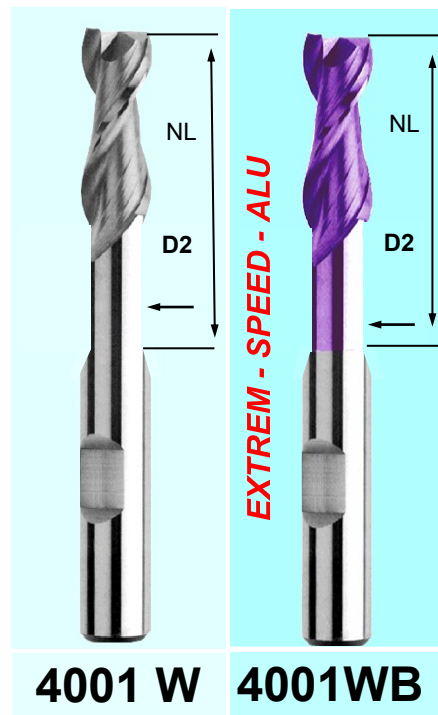
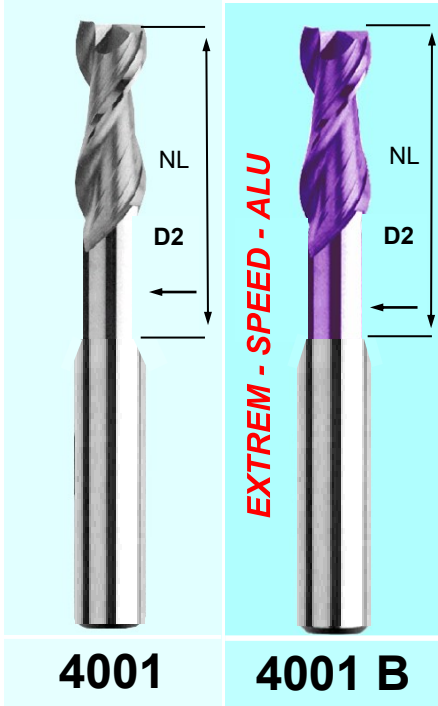

Typ
W

- Eintauchen und Längsfräsen von Keilnuten P9, für sämtliche ALU- und NE-Metalle sowie Kunststoffe und Kupfer.
- Mit diesem neuen **VHM - Ultra Fine - Fräser** wird eine um wesentlich grössere Zerspanungsleistung möglich.
- Höchstleistung mit neuer **EXTREM - SPEED - ALU - Beschichtung** für Aluminium.

Best.-Nr. 4001... 4001b... 4001w... 4001wb...	Thermo Plast. Alu	Alu	Alu Guss > 10% Si	Stahl < 750N	Stahl < 900N	Stahl < 1400N	Stahl < 55HRC	INOX	Ti + Cu	GG (G)	Uni- versal	4001 4001 W	4001 B 4001 WB
	Ø e ₈	Ecken- Radius	Sch.- länge	Ø D2 NL= Nutzlänge	Schaft- Ø	Ges.- länge	Z	4001 4001 W	4001 B 4001 WB				
..0300	3			10	2.8 x 20	3	57	2	33.00	39.60			
..0350	3.5			10	3.2 x 20	6	63	2	36.30	44.00			
..0400	4			15	3.2 x 26	6	63	2	36.30	44.00			
..0450	4.5			15	4.2 x 26	6	63	2	37.40	45.10			
..0500	5			20	4.6 x 30	6	63	2	37.40	45.10			
..0600	6			20	5.5 x 30	6	63	2	37.40	46.20			
..0800	8			28	7.4 x 36	8	72	2	47.30	56.10			
..1000	10			34	9.2 x 44	10	84	2	62.70	82.50			
..1200	12			40	11 x 52	12	97	2	95.70	119.90			
..1400	14			40	13 x 52	14	97	2	123.20	148.50			
..1600	16			48	15 x 60	16	108	2	152.90	181.50			
..2000	20			58	19 x 70	20	122	2	268.40	298.10			
..2500	25			58	24 x 70	25	122	2	385.00	469.70			

4001

4001 B

4001 W

4001 WB

EXTREM - SPEED - ALU
beschichtet

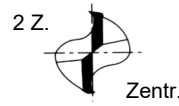
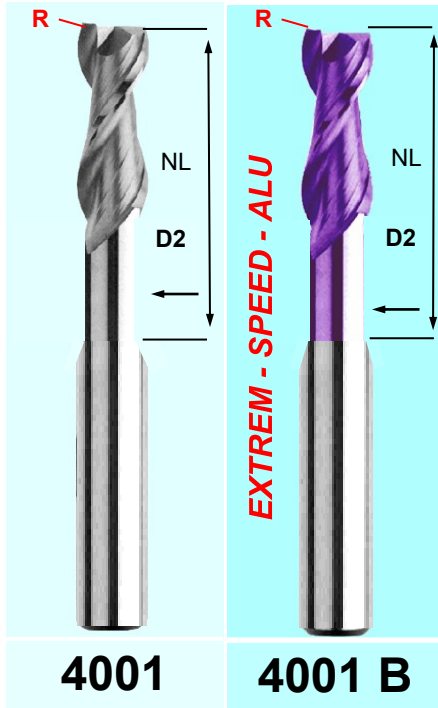

Typ
W

- Eintauchen und Längsfräsen von Keilnuten P9, für sämtliche ALU- und NE-Metalle sowie Kunststoffe und Kupfer.
- Mit diesem neuen **VHM - Ultra Fine - Fräser** wird eine um wesentlich grössere Zerspanungsleistung möglich.
- Höchstleistung mit neuer **EXTREM - SPEED - ALU - Beschichtung** für Aluminium.

Best.-Nr. 4001... 4001b... 4001w... 4001wb...	Thermo Plast. Alu	Alu > 10% Si	Stahl < 750N	Stahl < 900N	Stahl < 1400N	Stahl < 55HRC	INOX	Ti + Cu	GG (G)	Uni- versal	4001 4001 W	4001 B 4001 WB
	Ø e ₈	Ecken- Radius	Sch.- länge	Ø D2 NL= Nutzlänge	Schaft- Ø	Ges.- länge	Z	4001R 4001 WR	4001 BR 4001 WBR			
..030003	●	●									37.40	45.10
..035003	●	●									40.70	48.40
..040003	●	●									40.70	48.40
..045003	●	●									44.00	50.60
..050003	●	●									44.00	50.60
..060003	●	●									44.00	51.70
..060010	●	●									44.00	51.70
..080003	●	●									55.00	62.70
..080010	●	●									55.00	62.70
..100003	●	●									70.40	89.10
..100015	●	●									70.40	89.10
..120015	●	●									105.60	117.70
..140015	●	●									137.50	163.90
..160020	●	●									168.30	203.50
..200020	●	●									268.40	316.80
..250020	●	●									413.60	496.10

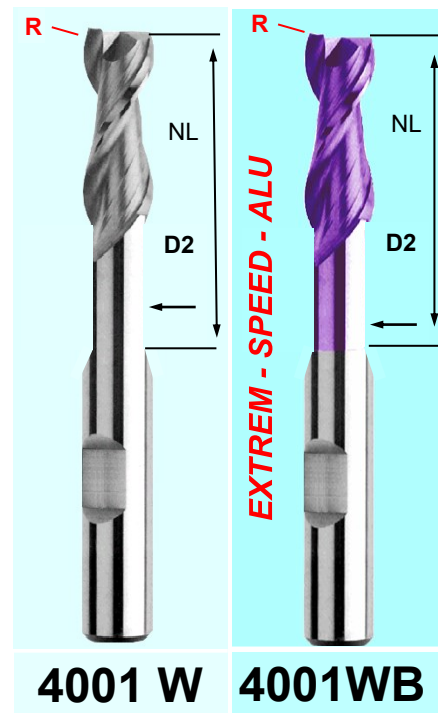

4003

4003 B

EXTREM - SPEED - ALU

beschichtet

Mit und ohne Eckenradius

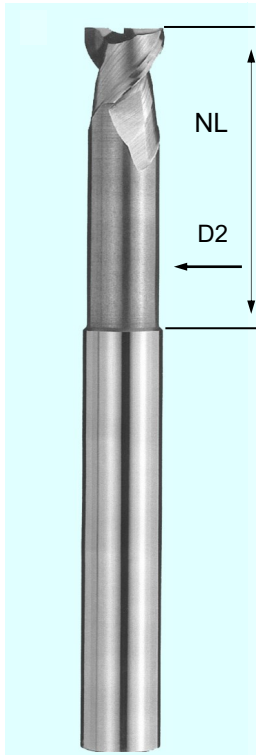

4003

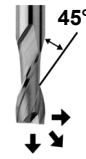
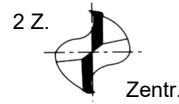

Typ
W

- Eintauchen und Längsfräsen für sämtliche ALU- und NE-Metalle sowie Kunststoffe und Kupfer.
- Geeignet zum **Hochgeschwindigkeitsfräsen**.
- Höchstleistung mit neuer **EXTREM - SPEED - ALU - Beschichtung** für Aluminium.
- Extra lange Ausführung mit **Eckenradius** und abgesetztem Schaft.
- Auch universell einsetzbar.

Mit und ohne Eckenradius

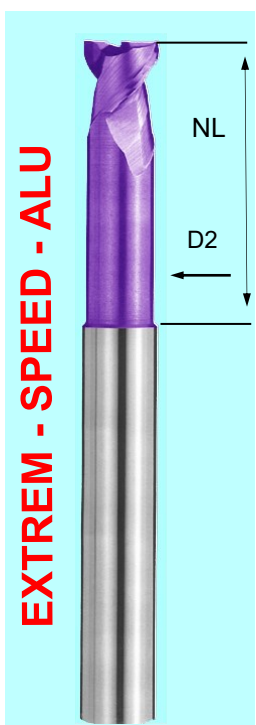

EXTREM - SPEED - ALU

4003 B

Best.-Nr. 4003... 4003b...	Thermo Plast. Alu	Alu Guss > 10% Si	Stahl < 750N	Stahl < 900N	Stahl < 1400N	Stahl < 55HRC	INOX	Ti + Cu	GG (G)	Uni- versal	4003	4003 B
	●	●						●		○		
	Ø e ₈	Ecken- Radius	Sch.- länge	Ø D2 NL= Nutzlänge	Schaft- Ø	Ges.- länge					4003	4003 B
..0300	3	—	6	2.5 x 20	3	75					46.20	52.80
..0400	4	—	6	3.5 x 20	6	75					46.20	52.80
..0500	5	—	6	4.5 x 25	6	100					47.30	58.30
..0600	6	—	6	5.5 x 30	6	100					47.30	59.40
..0800	8	—	6	7.4 x 35	8	100					63.80	74.80
..1000	10	—	10	9.2 x 40	10	100					84.70	104.50
..1200	12	—	12	11 x 98	12	100					94.60	118.80
..1600	16	—	12	15 x 55	16	125					178.20	214.50
..2000	20	—	16	18 x 65	20	150					273.90	322.30

4003R

4003 BR

EXTREM - SPEED - ALU

beschichtet

Mit und ohne Eckenradius

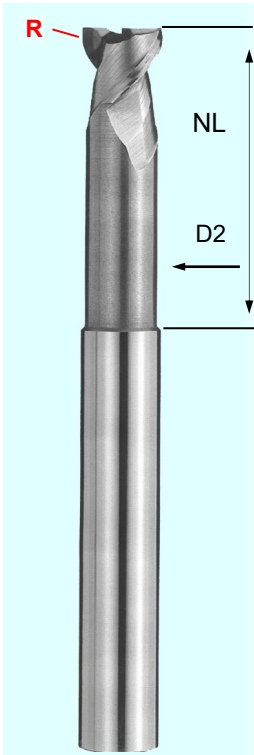

4003

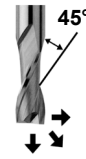
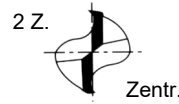

Typ
W

- Eintauchen und Längsfräsen für sämtliche ALU- und NE-Metalle sowie Kunststoffe und Kupfer.
- Geeignet zum **Hochgeschwindigkeitsfräsen**.
- Höchstleistung mit neuer **EXTREM - SPEED - ALU - Beschichtung** für Aluminium.
- Extra lange Ausführung mit **Eckenradius** und abgesetztem Schaft.
- Auch universell einsetzbar.

Mit und ohne Eckenradius

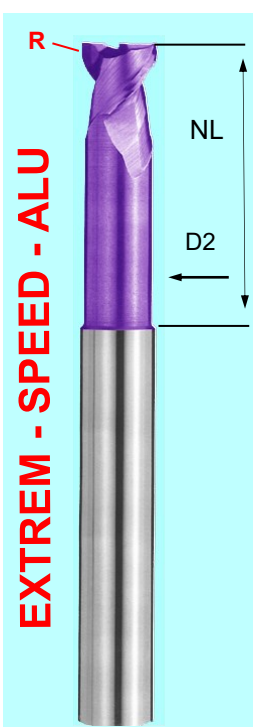

EXTREM - SPEED - ALU

4003 B

Best.-Nr. 4003... 4003b...	Thermo Plast. Alu	Alu Guss > 10% Si	Stahl < 750N	Stahl < 900N	Stahl < 1400N	Stahl < 55HRC	INOX	Ti + Cu	GG (G)	Uni- versal	4003R	4003 BR
	●	●						●		○		
	Ø e ₈	Ecken- Radius	Sch.- länge	Ø D2 NL= Nutzlänge	Schaft- Ø	Ges.- länge					4003R	4003 BR
..030003	3	0.3	6	2.5 x 20	3	75					51.70	59.40
..040003	4	0.3	6	3.5 x 20	6	75					51.70	59.40
..050003	5	0.3	6	4.5 x 25	6	100					55.00	63.80
..060003	6	0.3	6	5.5 x 30	6	100					55.00	64.90
..060010	6	1.0	6	5.5 x 30	6	100					55.00	64.90
..080003	8	0.3	6	7.4 x 35	8	100					71.50	83.60
..080010	8	1.0	6	7.4 x 35	8	100					71.50	83.60
..100003	10	0.3	10	9.2 x 40	10	100					93.50	122.20
..100015	10	1.5	10	9.2 x 40	10	100					93.50	122.20
..120015	12	1.5	12	11 x 50	12	100					103.40	127.60
..160020	16	2.0	12	15 x 55	16	125					191.40	227.70
..200020	20	2.0	16	18 x 65	20	150					273.90	331.10

4005

4005 B

EXTREM - SPEED - ALU

beschichtet



Typ
W

- Eintauchen und Längsfräsen für sämtliche ALU -und NE-Metalle sowie Kupfer.
- Höchstleistung mit neuer **EXTREM - SPEED - ALU - Beschichtung**.
- Universell einsetzbar.



Best.-Nr. 4005... 4005b...	Materialien										4005		4005 B					
	Thermo Plast. Alu	Alu	Alu Guss > 10% Si	Stahl < 750N	Stahl < 900N	Stahl < 1400N	Stahl < 55HRC	INOX	Ti + Cu	GG (G)	Uni-versal	Ø h ₁₀	Radius	Schneid-länge	Schaft-Ø	Ges.-länge	4005	4005 B
..0200	●	●	●						○	○		2.0	1.00	8	2.0	38	26.40	33.00
..0250	●	●	●						○	○		2.5	1.25	8	2.5	38	26.40	33.00
..0300	●	●	●						○	○		3.0	1.50	12	3.0	38	26.40	33.00
..0350	●	●	●						○	○		3.5	1.75	12	3.5	40	27.50	35.20
..0400	●	●	●						○	○		4.0	2.00	12	4.0	40	27.50	35.20
..0450	●	●	●						○	○		4.5	2.25	14	4.5	50	30.80	37.40
..0500	●	●	●						○	○		5.0	2.50	14	5.0	50	30.80	37.40
..0550	●	●	●						○	○		5.5	2.75	14	5.5	50	31.90	38.50
..0600	●	●	●						○	○		6.0	3.00	12	6.0	57	36.30	44.00
..0800	●	●	●						○	○		8.0	4.00	16	8.0	63	51.70	61.60
..1000	●	●	●						○	○		10.0	5.00	20	10.0	72	64.90	77.00
..1200	●	●	●						○	○		12.0	6.00	24	12.0	83	93.50	112.20
..1600	●	●	●						○	○		16.0	8.00	32	16.0	92	128.70	155.10
..2000	●	●	●						○	○		20.0	10.0	40	20.0	104	234.30	277.20

4006

HSC + 3 D

4006 B

extra lange Ausführung



- Universell einsetzbar
- Mit hinterschliffenem Schaft, für schwer zugängliche und tiefe Stellen.
- Speziell geeignet zum Kopierfräsen.
- Geeignet für Hochgeschwindigkeitsfräsen.
- Höchstleistung mit neuer **EXTREM - SPEED - ALU - Beschichtung**.

Best.-Nr. 4006... 4006b...	Materialien										4006		4006 B						
	Thermo Plast. Alu	Alu	Alu Guss > 10% Si	Stahl < 750N	Stahl < 900N	Stahl < 1400N	Stahl < 55HRC	INOX	Ti + Cu	GG (G)	Uni-versal	Ø h ₁₀	Radius	Schneid-länge	ØD2 NL=Nutzlänge	Schaft-Ø	Ges.-länge	4006	4006 B
..0200	●	●	●						○	○		2.0	1.0	4	1.8 x 12	6	75	49.50	57.20
..0300	●	●	●						○	○		3.0	1.5	6	2.8 x 15	6	75	49.50	57.20
..0400	●	●	●						○	○		4.0	2.0	8	3.7 x 18	6	75	47.30	55.00
..0500	●	●	●						○	○		5.0	2.5	10	4.6 x 25	6	80	47.30	55.00
..0600	●	●	●						○	○		6.0	3.0	12	5.5 x 30	6	80	47.30	71.50
..0800	●	●	●						○	○		8.0	4.0	16	7.4 x 35	8	80	61.60	70.40
..1000	●	●	●						○	○		10.0	5.0	20	9.2 x 40	10	100	85.80	105.60
..1200	●	●	●						○	○		12.0	6.0	24	11 x 50	12	120	116.60	140.80
..1600	●	●	●						○	○		16.0	8.0	32	15 x 55	16	160	198.00	234.30
..2000	●	●	●						○	○		20.0	10.0	40	19 x 60	20	160	334.40	382.80

VHM ALU-Schlichtfräser

HSC + Superfinish

4007 / 4008

4007 B / 4008 B

4007 W / 4008 W

4007 WB / 4008WB

EXTREM - SPEED - ALU beschichtet

EXTREM - SPEED - ALU beschichtet

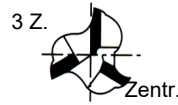

Typ
W

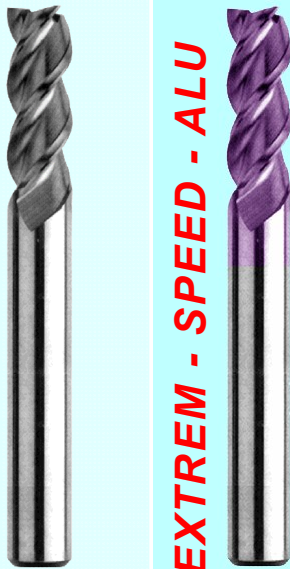

EXTREM - SPEED - ALU

4007

4007 B

4008

4008 B

- Ideal für Schlichtarbeiten mit höheren **Vorschüben und Schnittgeschwindigkeiten**, sowie für eine feinere Oberfläche (feinschichten).
- Höchstleistung mit neuer **EXTREM - SPEED - ALU - Beschichtung**, speziell für Aluminium.
- Für ALU -und alle NE-Metalle, Kunststoffe und Kupfer.
- Auch für **HSC** geeignet.

4007 Lange Schneide

Best.-Nr. 4007... 4007b... 4007w... 4007wb...	Alu	Alu Guss > 10% Si	Stahl < 750N	Stahl < 900N	Stahl < 1400N	Stahl < 55HRC	Stahl < 60HRC	Stahl < 67HRC	INOX	Ti + Cu	GG (G)	Uni- versal	4007 4007 W	4007 B 4007 WB
	●	●	○							●		●		
	Ø k ₁₀	Schneid- länge		Schaft- Ø		Ges.- länge		Z				4007 4007W	4007 B 4007WB	
.0300	3	12	6	57	3	23.10	28.60							
.0350	3.5	14	6	57	3	26.40	33.00							
.0400	4	14	6	57	3	23.10	28.60							
.0450	4.5	15	6	57	3	26.40	33.00							
.0500	5	16	6	57	3	25.30	33.00							
.0600	6	16	6	57	3	25.30	33.00							
.0700	7	20	8	63	3	33.00	42.90							
.0800	8	22	8	63	3	30.80	44.00							
.0900	9	25	10	72	3	47.30	59.40							
.1000	10	28	10	72	3	45.10	60.50							
.1200	12	32	12	80	3	60.50	80.30							
.1400	14	35	14	85	3	84.70	106.70							
.1600	16	45	16	90	3	119.90	146.30							
.1800	18	45	18	100	3	159.50	195.80							
.2000	20	50	20	100	3	191.40	234.30							

4008 Kurze Schneide

Best.-Nr. 4008... 4008b... 4008w... 4008wb...	Alu	Alu Guss > 10% Si	Stahl < 750N	Stahl < 900N	Stahl < 1400N	Stahl < 55HRC	Stahl < 60HRC	Stahl < 67HRC	INOX	Ti + Cu	GG (G)	Uni- versal	4008 4008 W	4008 B 4008 WB
	●	●	○							●		●		
	Ø k ₁₀	Schneid- länge		Schaft- Ø		Ges.- länge		Z				4008 4008W	4008 B 4008WB	
.0300	3	7	6	57	3	23.10	28.60							
.0350	3.5	7	6	57	3	26.40	33.00							
.0400	4	8	6	57	3	23.10	28.60							
.0450	4.5	8	6	57	3	26.40	33.00							
.0500	5	10	6	57	3	25.30	33.00							
.0600	6	10	6	57	3	25.30	33.00							
.0700	7	13	8	63	3	33.00	42.90							
.0800	8	16	8	63	3	30.80	44.00							
.0900	9	16	10	72	3	47.30	59.40							
.1000	10	19	10	72	3	45.10	60.50							
.1200	12	22	12	83	3	60.50	80.30							
.1400	14	22	14	83	3	84.70	106.70							
.1600	16	26	16	92	3	119.90	146.30							
.1800	18	26	18	92	3	159.50	195.80							
.2000	20	32	20	104	3	191.40	234.30							

4007 W

4007WB

4008 W

4008WB

VHM ALU-Schruppfräser

HSC + HPC

4009

4009 B

4009 W

4009 WB

EXTREM - SPEED - ALU beschichtet

EXTREM - SPEED - ALU beschichtet

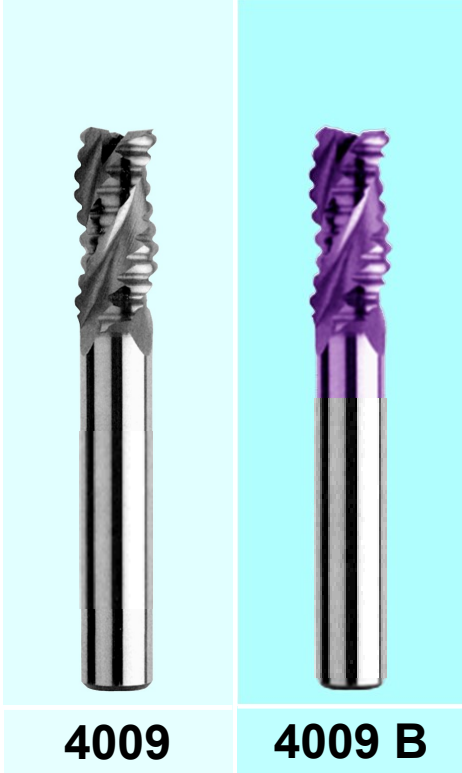

4009

4009 B



Typ
WR

für ALU

- Hohe Zerspanungsleistung mit grossen Spanräumen; für alle ALU- und NE-Metalle, Kunststoffe und Kupfer.
- Höchstleistung mit **Alu - EXTREM - SPEED - ALU - Beschichtung**, speziell für Aluminium. Doppelte Zerspanungsleistung durch spez. Verzahnung für Alu.
- Auch für HSC geeignet.
- Doppelte Zerspanungsleistung durch spez. Verzahnung für Alu.



4009 W

4009 WB

	Thermo Plast. Alu	Alu	Alu Guss > 10% Si	Stahl < 750N	Stahl < 900N	Stahl < 1400N	Stahl < 55HRC	INOX	Ti + Cu	GG (G)	Uni-versal	4009 4009 W	4009 B 4009 WB
Best.-Nr. 4009... 4009b... 4009w... 4009wb...	●	●	●						●				
	Ø js12	Schneid- länge	Schaft- Ø	Ges.- länge	Z								
..0600	6	16	6	57	3							47.30	56.10
..0700	7	16	8	63	3							56.10	66.00
..0800	8	16	8	63	3							56.10	64.90
..0900	9	19	10	72	3							74.80	88.00
..1000	10	22	10	72	3							74.80	88.00
..1200	12	26	12	83	3							94.60	116.60
..1400	14	26	14	83	3							123.20	147.40
..1600	16	32	16	92	3							141.90	169.40
..1800	18	32	18	92	3							190.30	226.60
..2000	20	38	20	104	3							260.70	303.60
..2500	25	45	25	121	3							385.00	445.50



3095

HSC

3095 B EXTREM - SPEED - ALU

beschichtet

- zum Einstechen und Konturen fräsen

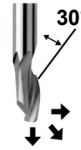
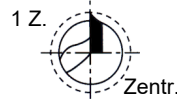
 Typ
N

Best.-Nr. 3095... 3095b...	Material										3095	3095 B
	Alu Guss > 10% Si	Stahl < 750N	Stahl < 900N	Stahl < 1400N	Stahl < 55HRC	Stahl < 60HRC	Stahl < 67HRC	INOX	Ti + Cu	GG (G)	Uni- versal	3095
Ø js14	Schneid- länge	Schaft- Ø	Gesamt- länge		3095		3095 B					
..020010	2.0	10	2.0	38	23.10	28.60						
..025012	2.5	12	3.0	38	25.30	31.90						
..030012	3.0	12	3.0	38	23.10	28.60						
..040015	4.0	15	4.0	40	26.40	34.10						
..050016	5.0	16	5.0	50	33.00	40.70						
..060018	6.0	18	6.0	50	35.20	44.00						
..060025	6.0	25	6.0	57	40.70	49.50						
..080022	8.0	22	8.0	63	51.70	61.60						
..080040	8.0	40	8.0	80	64.90	77.00						
..100030	10.0	30	10.0	72	80.30	92.40						
..120030	12.0	30	12.0	73	108.90	128.70						
..140032	14.0	32	14.0	75	157.30	183.70						
..160032	16.0	32	16.0	82	182.60	210.10						
..180038	18.0	38	18.0	84	239.80	276.10						
..200040	20.0	40	20.0	104	287.10	349.80						

VHM Einzahnfräser für Kunststoff

3096

HSC

3096 B EXTREM - SPEED - ALU

beschichtet

- Speziell für Kunststoff



Best.-Nr. 3096... 3096b...	Material										3096	3096 B
	Thermo Plast. Alu	Alu Guss > 10% Si	Stahl < 750N	Stahl < 900N	Stahl < 1400N	Stahl < 55HRC	INOX	Ti + Cu	GG (G)	Uni- versal	3096	3096 B
Ø js14	Schneid- länge	Schaft- Ø	Gesamt- länge		3096		3096 B					
..020010	2.0	10	2.0	38	23.10	28.60						
..025012	2.5	12	3.0	38	25.30	31.90						
..030012	3.0	12	3.0	38	23.10	28.60						
..040015	4.0	15	4.0	40	26.40	34.10						
..050016	5.0	16	5.0	50	33.00	40.70						
..060018	6.0	18	6.0	50	35.20	44.00						
..060025	6.0	25	6.0	57	40.70	49.50						
..080022	8.0	22	8.0	63	51.70	61.60						
..080040	8.0	40	8.0	80	64.90	77.00						
..100030	10.0	30	10.0	72	80.30	92.40						
..120030	12.0	30	12.0	73	108.90	128.70						
..140032	14.0	32	14.0	75	157.30	183.70						
..160032	16.0	32	16.0	82	182.60	210.10						
..180038	18.0	38	18.0	84	239.80	276.10						
..200040	20.0	40	20.0	104	287.10	349.80						

VHM X-V-10 Schaftfräser

Mit ungleicher Teilung & Drillwinkelsteigung

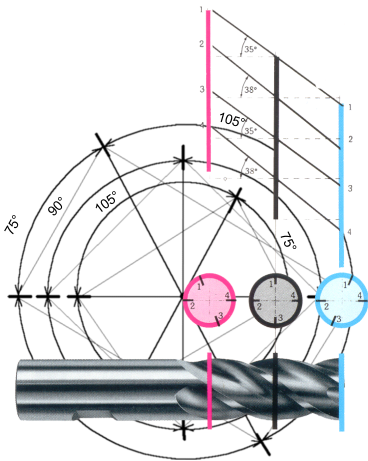

- Schichten
- Schruppen
- Schruppschichten mit einem Werkzeug!

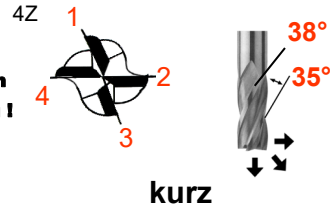

MC3
Beschichtet

7500 WB

- Bis zu 60° höhere Zerspanungsleistung
- Vibrationsfreies Laufen
- Bessere Oberfläche
- Höhere Standzeiten
- Universal einsetzbar für sämtliche Werkstoffe.



Best.-Nr. 7500wb...	Ø h ₁₀	Schneid- länge	Schaft- durchmesser	Gesamt- länge	Zähne	7500 WB
..0600	6	10	6	54	4	25.30
..0800	8	12	8	58	4	34.10
..1000	10	14	10	66	4	48.40
..1200	12	16	12	73	4	60.50
..1400	14	18	14	75	4	75.90
..1600	16	22	16	82	4	100.10
..1800	18	24	18	84	4	154.00
..2000	20	26	20	92	4	161.70



**Lang
mit und ohne
Ecken-Radius**

7550 WB

Best.-Nr.
7550wb...

	Thermo Plast. Alu	Alu	Alu Guss > 10% Si	Stahl < 750N	Stahl < 900N	Stahl < 1400N	Stahl < 55HRC	INOX	GG (G)	Ti + Cu	Universal
Best.-Nr. 7550wb...	Ø e ₈	Ecken- Radius	Sch.-länge	Schaft- Ø	Ges.-länge	Z	7550 WB				
..040002	4	0.2	11	6	50	4					
..050002	5	0.2	13	6	50	4					
..0600	6	—	13	6	57	4					
..060002	6	0.2	13	6	50	4					
..060005	6	0.5	13	6	50	4					
..060010	6	1.0	13	6	50	4					
..0800	8	—	19	8	63	4					
..080002	8	0.2	19	8	60	4					
..080005	8	0.5	19	8	60	4					
..080010	8	1.0	19	8	60	4					
..1000	10	—	22	10	72	4					
..100003	10	0.3	22	10	70	4					
..100010	10	1.0	22	10	70	4					
..100015	10	1.5	22	10	70	4					
..1200	12	—	26	12	83	4					
..120003	12	0.3	26	12	75	4					
..120010	12	1.0	26	12	75	4					
..120015	12	1.5	26	12	75	4					
..1400	14	—	26	14	83	4					
..140003	14	0.3	26	14	80	4					
..1600	16	—	32	16	92	4					
..160003	16	0.3	32	16	90	4					
..160015	16	1.5	32	16	90	4					
..160020	16	2.0	32	16	90	4					
..1800	18	—	32	18	92	4					
..180003	18	0.3	32	18	100	4					
..2000	20	—	38	20	104	4					
..200003	20	0.3	38	20	100	4					
..200030	20	3.0	38	20	100	4					

Obwohl konstruktiv ein kompliziertes Werkzeug, ist das Nachschleifen auf CNC Maschinen kein Problem!

SCHNITTWERTE

LEGENDE

Code-Buchst.	K	L	M	N	O	P	Q	R	S	T	U	Code-Buchst.	
Fräser-Ø mm	6,00	0,017	0,024	0,021	0,025	0,031	0,029	0,033	0,039	0,036	0,041	0,047	Vorschub f _z (mm/z)
	8,00	0,024	0,032	0,031	0,035	0,042	0,042	0,047	0,053	0,052	0,058	0,064	
	10,00	0,030	0,038	0,039	0,044	0,051	0,053	0,059	0,065	0,066	0,073	0,080	
	12,50	0,036	0,046	0,048	0,052	0,059	0,063	0,072	0,079	0,080	0,089	0,100	
	16,00	0,045	0,054	0,058	0,063	0,071	0,079	0,088	0,095	0,100	0,110	0,120	
	20,00	0,057	0,066	0,073	0,081	0,089	0,097	0,106	0,114	0,120	0,130	0,139	

Rosa unterlegte Vorschub-Reihen-Codebuchstaben (d.h. die kurze Fräserausführung) sind bevorzugt einzusetzen, wenn es die Fräseraufgabe gestattet.

Für den Anbohr- Vorschub bei Fräsem mit Mitteschnitt gelten 30% der hier angegebenen normalen Vorschub- werte :
 $f_{za} = 0,3 \times f_z$

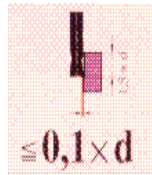

Feinschichten

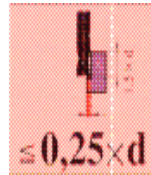
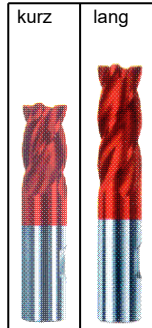

Schichten

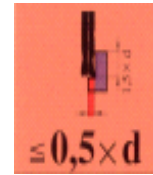
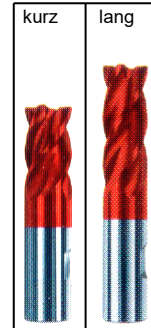

Schruppschichten

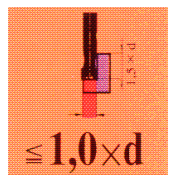
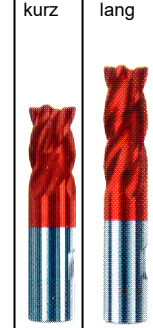

Schruppen

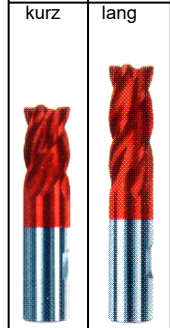

Werkstoffgruppe	Werkstoffbeispiele, neue Bezeichnung (Fettgedruckte Zahlen = Werkstoffe Nr. nach DIN)	Zugfestig- keit	Vc m/min	Vorschub Reihencode		Vc m/min	Vorschub Reihencode		Vc m/min	Vorschub Reihencode		Vc m/min	Vorschub Reihencode	
				P	O		P	O		P	O		P	O
Allgemeine Baustähle	10035 S185 (St33), 10486 P275N (StE285), 10345 10050 E295 (St50-2), 10070 E360 (St70-2), 18937	>500 >580	350 275	P O	O N	300 235	P O	O N	296 235	Q P	P O	282 223	R Q	Q P
Automatenstähle	10718 11SMnPb30, 10736 115Mn37 10727, 10728 (60 S20), 10757	>800 >1000	275 265	O N	N M	235 230	O N	N M	235 224	P O	O N	223 214	Q P	P O
Unlegierte Vergütungsstähle	10402 C22, 11178 Ck30E 10503 C45, 11191 Ck45E 10601 C60, 11221 Ck60E	<700 <850 <1000	300 275 265	P O N	O N M	260 235 230	P O N	O N M	235 235 224	Q P O	P O N	223 223 214	R Q P	Q P O
Legierte Vergütungsstähle	15131 50MnSi4, 17003 38Cr2, 17030 28Cr4 15710 36NiCr6, 17035 41Cr4, 17225 42CrMo4	<1000 <1200	265 230	N M	M L	230 190	N M	M L	224 194	O N	N M	214 185	P O	O N
Unlegierte Einsatz- stähle.	10301 (C10), 11121 C10E	<700	350	P	O	300	P	O	296	Q	P	282	R	Q
Nitrierstähle	18504 34CrA16 18519 31CrMoV9, 18550 34CrA1Ni7	<1000 <1200	265 230	N M	M L	230 190	N M	M L	224 194	O N	N M	214 185	P O	O N
Werkzeugstähle	11750 C75W, 12067 102Cr6, 12307 29CrMoV9 12080 X210Cr12, 12083 X42Cr13, 12419 105WCr6,	<850 <1000	275 265	N M	M L	240 230	N M	M L	235 224	O N	N M	223 214	P O	O N
Schnellarbeitsstähle	13243 S 6-5-2-5, 13343 S 6-5-2, 13344 61CrV4	650-1000	155	M	L	130	M	L	132	N	M	126	O	N
Federstähle	15026 55Si7, 17176 55Cr3, 18159 51CrV4	<330HB	155	M	L	130	M	L	132	N	M	126	O	N
Rostfreie Stähle, geschwef., austenitisch, martensitisch	14005 X12CrS13, 14104 X14CrMoS17, 14105 14301 X5CrNi18 10, 14541 X6CrNiTi18 10, 14571 14057 X17CrNi16-1, 14122 X39CrMo17-1, 14521	<850	190 155 155	N M N	M L M	160 130 130	N M N	M L M	163 132 132	O N O	N M N	155 126 126	P O P	O N O
Gehärtete Stähle	-	40-60 HRC												
Sonderlegierungen	Nimonic, Inconel, Monel, Hastelloy	<1200	110	L	K	90	L	K	91	M	N	87	N	M
Gusseisen	06010 EN GJL-100 (GG10), 06020 EN GJL-200 (GG20) 06025 EM GJL-250 (GG25), 06035 EN GJL-350 (GG35)	<240HB <300HB	240 155	R Q	Q P	205 130	R Q	Q P	204 180	S R	R Q	194 126	T S	S R
Kugelgraphit und Temperguss	07050 EN-GJS-500-7) (GGG50), 08035 GJMw-350-4 07070 EN-GJS-700 (GGG70), 08170 EN-GJMB-700-2	<240HB <300HB	190 155	R Q	Q P	160 130	R Q	Q P	163 132	R Q	Q P	155 126	S R	R Q
Hartguss		<350HB	110	M	L	90	M	L	92	N	M	88	O	N
Titan und Titan- legierungen	37024 Ti99,5 37114 TiAl15Sn2,5m 37124 TiCu2 37154 TiAl16Zr5, 37164 TiAl6V4, 37184 TiAl4Mo4Sn2,5	<850 <1200	240 155	M L	L K	205 130	M L	L K	204 132	N M	M L	194 126	O N	N M
Aluminium	30255 A1995, 5 32315 AlMgSi1, 33515 AlMg1	<400	1080	R	Q	900	R	Q	918	S	R	873	T	S
Al-Knetlegierungen	30615 A1MgSiPb, 31325 AlCuMg1, 33245 AlMg3Si,	<450	1320	R	Q	1080	R	Q	1122	S	R	1066	T	S
Magnesium Leg.	MgMn2, G-MgAl8Zn1, G-MgAl6Zn3	<450	360	R	Q	300	R	Q	306	S	R	290	T	S
Kupfer, niedriglegiert	20070 SE-Cu, 21020 CuSn6, 21096 G-CuSn5ZnPb	<400	335	R	Q	290	R	Q	286	S	R	271	T	S
Messing, kurzspanend langspanend	20380 CuZn39Pb2, 20041 CuZn39Pb3, 20410 CuZn43 20250 CuZn20, 20280 CuZn33	<600 <600	470 360	P P	P O	395 300	P P	P O	397 306	Q P	P O	377 290	R R	Q Q
Bronzen, kurzspanend	21090 CuSn7ZnPb, 21170 CuPb5Sn5, 21176 CuPb10Sn, 20790 C4Ni18Zn19Pb	<600 <850	470 360	P O	P O	395 300	P O	P O	397 306	Q P	P O	377 290	R Q	Q P
Bronzen, langspanend	20916 CuAl15, 20960 CuAl19Mn, 21050 CuSn10	<850	360	O	O	360	O	O	306	P	O	290	Q	P
Kunststoffe, duropl, thermopl.	Bakelit, Resopal, Pertinax, Moltopren Plexiglas, Hostalen, Novodur, Makrolon	- -	275 160	L L	L L	235 140	L L	L L	234 138	M M	L L	222 131	N N	M M
Kunststoffe, aramid, glas, kohlef.	Kevlar GFK / CFK	- -	230 230	L K	L K	190 190	L K	L K	194 194	M L	L K	214 214	N M	M L

DIAMOND

Art.-Nr. 3098

H S C

Diamant
VHM - Fräser



Bestell-Nr.
3098...

	Ø	Radius	Schneid- länge	Schaft- Ø	Gesamt- länge	Zähne
..0200	2	1,0	4	3	100	2
..0300	3	1,5	14	3	100	2
..0400	4	2	14	4	100	2
..0500	5	2,5	20	5	100	2
..0600	6	3	40	6	100	2
..0800	8	4	40	8	100	2
..1000	10	5	40	10	150	2
..1200	12	6	45	12	150	2

* 10 x höhere Standzeiten als VHM – Werkzeuge

* Bessere Standzeiten als PKD – Werkzeuge

DIAMOND

Art.-Nr. 3099

H S C

Diamant
VHM - Fräser



lange
Ausführung



Bestell-Nr.
3099...

	Ø	Ecken- radius	Schneid- länge	Schaft- Ø	Gesamt- länge	Zähne
..0300	3	0.3	8	3	60	2
..0400	4	0.3	9	4	100	2
..0500	5	0.5	11	5	100	2
..0600	6	0.5	25	6	100	2
..0800	8	0.5	25	8	100	2
..1000	10	0.5	25	10	150	2
..1200	12	1.0	30	12	150	2

* 10 x höhere Standzeiten als VHM – Werkzeuge

* Bessere Standzeiten als PKD – Werkzeuge

Neue Masstäbe bei der Bearbeitung von Graphit , faserverstärkte Kunststoffe ,
Alu - Legierungen mit 15 % Silizium ,
Kupfer , Messing , Edelmetalle und Grauguss GGG.
Mit einer Mikrohärtigkeit von - 10000 HV - zerspannen Sie alle schwer
zerspanbaren Nichteisenmetalle in kürzester Zeit.

4010

4010 B

EXTREM - SPEED

beschichtet

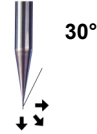
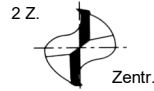

Typ
N

- Universal einsetzbar für sämtliche Werkstoffe
- Gute Eigenschaft zum **Trockenfräsen**, auch zum **HSC-Fräsen** geeignet.
- Höchstleistung mit **X-TREME - Beschichtung**.



4010



4010 B

Best.-Nr. 4010... 4010B... 4015... 4015B...	Alu	Alu Guss >	Stahl < 750N	Stahl < 900N	Stahl < 1400N	Stahl < 55HRC	INOX	Ti + Cu	GG (G)	Uni- versal	4010	4010B	4015 mit Radius	4015B mit Radius
	Ø e ₈	Schneid- länge	Schaft- Ø	Gesamt- länge	Radius	4010	4010 B	4015	4015 B					
..0010	0,1	0,2	3	38	0,05	116.60	—	112.20	—					
..0020	0,2	0,5	3	38	0,10	60.50	69.30	85.80	94.60					
..0030	0,3	1,0	3	38	0,15	38.50	47.30	71.50	80.30					
..0040	0,4	1,0	3	38	0,20	38.50	47.30	42.80	61.60					
..0050	0,5	1,5	3	38	0,25	33.00	42.90	39.60	49.50					
..0060	0,6	1,5	3	38	0,30	33.00	42.90	39.60	49.50					
..0070	0,7	2,0	3	38	0,35	33.00	42.90	39.60	49.50					
..0080	0,8	2,0	3	38	0,40	33.00	42.90	42.90	50.60					
..0090	0,9	2,5	3	38	0,45	33.00	42.90	42.90	50.60					
..0100	1,0	3,0	3	38	0,50	31.90	39.60	42.90	50.60					
..0110	1,1	3,0	3	38	0,55	33.00	42.90	42.90	50.60					
..0120	1,2	4,0	3	38	0,60	33.00	42.90	42.90	50.60					
..0130	1,3	4,0	3	38	0,65	33.00	42.90	42.90	50.60					
..0140	1,4	4,0	3	38	0,70	33.00	42.90	47.30	50.60					
..0150	1,5	4,0	3	38	0,75	31.90	39.60	39.60	49.50					
..0160	1,6	5,0	3	38	0,80	31.90	39.60	39.60	49.50					
..0170	1,7	5,0	3	38	0,85	33.00	42.60	—	—					
..0180	1,8	5,0	3	38	0,90	33.00	42.60	39.60-	49.50					
..0190	1,9	5,0	3	38	0,95	33.00	42.60	—	—					
..0200	2,0	5,0	3	38	1,00	31.90	39.60	39.60	49.50					
..0210	2,1	6,0	3	38	1,05	36.30	47.30	—	—					
..0220	2,2	6,0	3	38	1,10	36.30	47.30	—	—					
..0230	2,3	6,0	3	38	1,15	36.30	47.30	—	—					
..0240	2,4	6,0	3	38	1,20	36.30	47.30	—	—					
..0250	2,5	7,0	3	38	1,25	33.00	42.90	42.90	50.60					
..0260	2,6	7,0	3	38	1,30	38.50	47.30	—	—					
..0270	2,7	7,0	3	38	1,35	38.50	47.30	—	—					
..0280	2,8	7,0	3	38	1,40	38.50	47.30	—	—					
..0290	2,9	7,0	3	38	1,45	38.50	47.30	—	—					
..0300	3,0	10,0	4	44	1,50	38.50	47.30	42.90	50.60					

VHM MICRO – Fräser mit RADIUS



4015

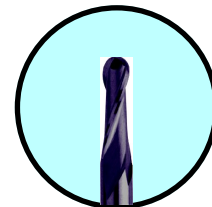

4015 B

4017 B

EXTREM - SPEED

beschichtet

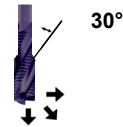
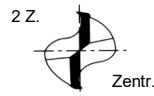

Typ
N



- Extra preisgünstiger Hochleistungsfräser.
- Speziell lange VHM - Micro - Fräser mit abgesetztem Schaft.
- Auch für schwerzerspanbare Materialien - 62 HRC geeignet.
- Mit diesem neuen **VHM - Ultra Fine - Fräser** wird eine wesentlich grössere Zerspanungsleistung möglich.
- Höchstleistung mit **EXTREM - SPEED - Beschichtung**.
- Geeignet für HSC **Hochgeschwindigkeitsfräsen**.

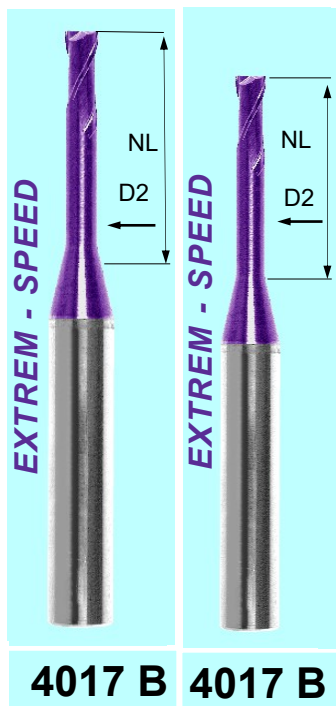

4017 B

4017 B

Best.-Nr. 4017b...	Alu	Alu Guss > 10% Si	Stahl < 750N	Stahl < 900N	Stahl < 1400N	Stahl < 55HRC	Stahl < 60HRC	Stahl < 67HR C	INOX	Ti > 850N	GG (G)	Uni- versal	4017 B
	Ø e ₉	Schneiden- länge	Ø D2 NL= Nutzlänge	Schaft- Ø	Ges.- länge	4017							
..00500200	0.5	0.7	0.45 x 2	4	45	31.90							
..00500600	0.5	0.7	0.45 x 6	4	45	36.30							
..00600200	0.6	0.9	0.55 x 2	4	45	31.90							
..00600600	0.6	0.9	0.55 x 6	4	45	36.30							
..00800400	0.8	1.2	0.75 x 4	4	45	31.90							
..00800800	0.8	1.2	0.75 x 8	4	45	36.30							
..01000600	1.0	1.5	0.95 x 6	4	45	26.40							
..01001000	1.0	1.5	0.95 x 10	4	45	31.90							
..01001200	1.0	1.5	0.95 x 12	4	45	31.90							
..01200600	1.2	1.8	1.15 x 6	4	45	26.40							
..01201000	1.2	1.8	1.15 x 10	4	45	31.90							
..01201200	1.2	1.8	1.15 x 12	4	45	31.90							
..01500600	1.5	2.3	1.45 x 6	4	45	26.40							
..01501000	1.5	2.3	1.45 x 10	4	45	26.40							
..01501400	1.5	2.3	1.45 x 14	4	50	36.30							
..01501800	1.5	2.3	1.45 x 18	4	55	36.30							
..02000600	2.0	3.0	1.95 x 6	4	45	26.40							
..02001000	2.0	3.0	1.95 x 10	4	45	26.40							
..02001400	2.0	3.0	1.95 x 14	4	50	31.90							
..02001800	2.0	3.0	1.95 x 18	4	55	34.10							
..02002500	2.0	3.0	1.95 x 25	4	60	37.40							
..02500800	2.5	3.7	2.4 x 8	4	45	26.40							
..02501200	2.5	3.7	2.4 x 12	4	45	26.40							
..02501600	2.5	3.7	2.4 x 16	4	50	31.90							
..02502000	2.5	3.7	2.4 x 20	4	55	37.40							
..02503000	2.5	3.7	2.4 x 30	4	70	37.40							
..03000800	3.0	4.5	2.85 x 8	6	45	27.50							
..03001200	3.0	4.5	2.85 x 12	6	45	27.50							
..03001600	3.0	4.5	2.85 x 16	6	50	34.10							
..03001600	3.0	4.5	2.85 x 20	6	55	40.70							
..03002000	3.0	4.5	2.85 x 20	6	55	40.70							
..03003000	3.0	4.5	2.85 x 30	6	70	40.70							
..03004000	3.0	4.5	2.85 x 40	6	90	51.70							

4018 B

EXTREM - SPEED

beschichtet

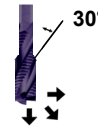
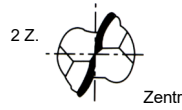

Typ
N



- Extra preisgünstiger Hochleistungsfräser.
- Speziell lange VHM - Micro - Fräser mit abgesetztem Schaft.
- Vollradius auch zu Kopierfräser.
- Auch für schwerzerspanbare Materialien - 62 HRC geeignet.
- Mit diesem neuen **VHM - Ultra Fine - Fräser** wird eine wesentlich grössere Zerspanungsleistung möglich.
- Höchstleistung mit **EXTREM - SPEED - Beschichtung**.
- Geeignet für HSC **Hochgeschwindigkeitsfräser**.



Best.-Nr.
4018b...

	Alu	Alu Guss > 10% Si	Stahl < 750N	Stahl < 900N	Stahl < 1400N	Stahl < 55HRC	Stahl < 60HRC	Stahl < 67HRC	INOX	Ti > 850N	GG (G)	Uni- versal	4018 B
	○	●	●	●	●	●	●	●	○	○	○	○	
Ø _{e8}	Radius	Schneiden- länge		Ø D2 NL= Nutzlänge		Schaft- Ø	Ges.- länge		4018 B				
...00500200	0.5	0.25	0.5	0.45 x 2	4	45	43.60						
...00500400	0.5	0.25	0.5	0.45 x 4	4	45	43.60						
...00500600	0.5	0.25	0.5	0.45 x 6	4	45	44.60						
...00600200	0.6	0.3	0.6	0.55 x 2	4	45	43.60						
...00600400	0.6	0.3	0.6	0.55 x 4	4	45	43.60						
...00600600	0.6	0.3	0.6	0.55 x 6	4	45	44.90						
...00800200	0.8	0.4	0.8	0.75 x 2	4	45	43.60						
...00800400	0.8	0.4	0.8	0.75 x 4	4	45	43.60						
...00800600	0.8	0.4	0.8	0.75 x 6	4	45	44.90						
...00800800	0.8	0.4	0.8	0.75 x 8	4	45	44.90						
...01000300	1.0	0.5	1.0	0.95 x 3	4	45	39.30						
...01000600	1.0	0.5	1.0	0.95 x 6	4	45	39.60						
...01000800	1.0	0.5	1.0	0.95 x 8	4	45	42.30						
...01001000	1.0	0.5	1.0	0.95 x 10	4	45	44.90						
...01001200	1.0	0.5	1.0	0.95 x 12	4	45	44.90						
...01200600	1.2	0.6	1.2	1.15 x 6	4	45	39.60						
...01200800	1.2	0.6	1.2	1.15 x 8	4	45	42.30						
...01201000	1.2	0.6	1.2	1.15 x 10	4	45	44.90						
...01201200	1.2	0.6	1.2	1.15 x 12	4	45	44.90						
...01500800	1.5	0.75	1.5	1.45 x 8	4	45	42.30						
...01501200	1.5	0.75	1.5	1.45 x 12	4	45	44.90						
...01501600	1.5	0.75	1.5	1.45 x 16	4	50	44.90						
...01502000	1.5	0.75	1.5	1.45 x 20	4	55	48.90						
...02000400	2.0	1.0	2.0	1.95 x 4	4	45	42.30						
...02000800	2.0	1.0	2.0	1.95 x 8	4	45	42.30						
...02001200	2.0	1.0	2.0	1.95 x 12	4	45	44.90						
...02002000	2.0	1.0	2.0	1.95 x 20	4	55	48.90						
...03000800	3.0	1.5	3.0	2.85 x 8	6	50	48.90						
...03001200	3.0	1.5	3.0	2.85 x 12	6	50	48.90						
...03002000	3.0	1.5	3.0	2.85 x 20	6	60	60.70						
...03003000	3.0	1.5	3.0	2.85 x 30	6	70	63.40						
...04001000	4.0	2.0	4.0	3.85 x 10	6	60	60.70						
...04002000	4.0	2.0	4.0	3.85 x 20	6	65	63.40						
...04003000	4.0	2.0	4.0	3.85 x 30	6	80	73.90						
...04004000	4.0	2.0	4.0	3.85 x 40	6	90	80.50						

VHM Mini-3-Schneiden-Fräser kurz

4020 W

4020 WB

EXTREM - SPEED

beschichtet

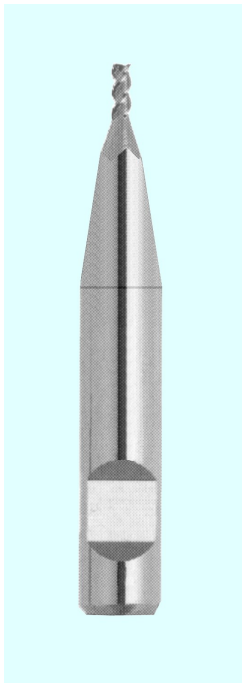

4020 W



4020 WB

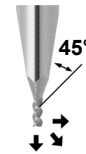

Typ
N

- Universal einsetzbar für sämtliche Werkstoffe;
- Gute Eigenschaft zum **Trockenfräsen**.
- Mit diesem neuen **VHM - Ultra Fine - Fräser** wird eine wesentlich grössere Zerspanungsleistung möglich.
- Höchstleistung mit **EXTREM - SPEED - Beschichtung**.
- Auch geeignet zum **Hochgeschwindigkeitsfräsen**.

Best.-Nr. 4020w... 4020wb...	Alu	Alu Guss > 10% Si	Stahl < 750N	Stahl < 900N	Stahl < 1400N	Stahl < 55HRC	Stahl < 60HRC	Stahl < 67HRC	INOX	Ti > 850N	GG (G)	Uni- versal	4020 W	4020 WB
	○	●	●	●	●	●	●	●	●	●	●	●		
	Ø e ₈	Schneid- länge	Schaft- Ø	Gesamt- länge	Z									
..0200	2	4	6	35	3	19.70	25.30							
..0250	2,5	5	6	36	3	20.80	27.50							
..0300	3	5	6	36	3	19.70	25.30							
..0350	3,5	7	6	38	3	20.80	27.50							
..0400	4	7	6	38	3	19.70	25.30							
..0450	4,5	8	6	39	3	20.80	27.50							
..0500	5	8	6	39	3	19.70	25.30							
..0550	5,5	8	6	39	3	23.10	27.50							
..0600	6	8	6	39	3	19.70	27.50							
..0700	7	11	8	43	3	31.20	39.60							
..0800	8	11	8	43	3	31.20	39.60							
..0900	9	13	10	50	3	45.10	64.90							
..1000	10	13	10	50	3	45.10	64.90							



**Europe
force**

VHM Mini-3-Schneiden-Fräser lang

HSC

4030

4030 B

4030 W

4030 WB

EXTREM - SPEED

beschichtet

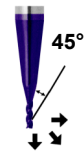

Typ
N

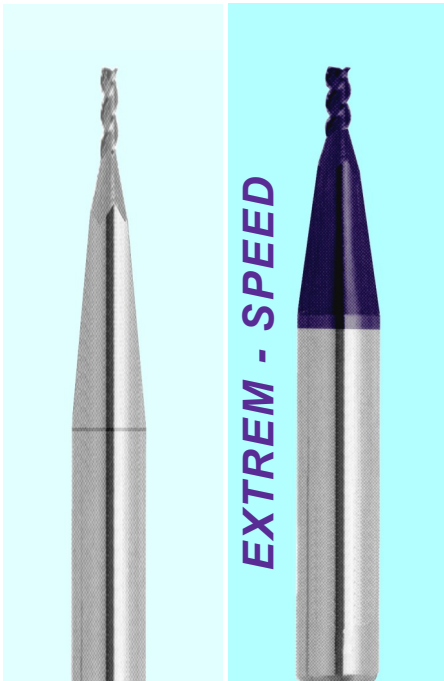

4030

4030 B

- Universal einsetzbar für sämtliche Werkstoffe;
- Gute Eigenschaft zum **Trockenfräsen**, auch zum **HSC-Fräsen** geeignet.
- Mit diesem neuen **VHM - Ultra Fine - Fräser** wird eine wesentlich grössere Zerspanungsleistung möglich.
- Höchstleistung mit **EXTREM - SPEED - Beschichtung**.
- Auch geeignet zum **Hochgeschwindigkeitsfräsen**.

Alu Alu Guss > 10% Si	Stahl < 750N	Stahl < 900N	Stahl < 1400N	Stahl < 55HRC	Stahl < 60HRC	Stahl < 67HR	INOX <	Ti > 850	GG (G)	Uni- versal	4030	4030 B
											4030 W	4030 WB
Ø	Schneid- länge		Schaft- Ø	Gesamt- länge		Z						
h ₁₀												
..0100	1	3	6	50	3	29.70	30.80					
..0150	1.5	3	6	50	3	29.70	30.80					
..0200	2	5	6	50	3	22.00	26.40					
..0250	2.5	4	6	50	3	26.40	31.90					
..0300	3	6	6	50	3	17.60	22.00					
..0350	3.5	8	6	50	3	24.20	30.80					
..0400	4	8	6	54	3	17.60	22.00					
..0450	4.5	8	6	54	3	24.20	30.80					
..0500	5	9	6	54	3	17.60	22.00					
..0550	5.5	7	6	54	3	24.20	30.80					
..0600	6	10	6	54	3	17.60	22.00					
..0700	7	11	8	58	3	30.80	37.40					
..0800	8	11	8	58	3	23.10	28.60					
..0900	9	13	10	66	3	45.10	59.40					
..1000	10	13	10	66	3	30.80	38.50					
..1200	12	14	12	73	3	46.20	57.20					
..1400	14	16	14	75	3	77.00	90.20					
..1600	16	18	16	82	3	102.30	127.60					
..1800	18	20	18	84	3	173.80	200.20					
..2000	20	22	20	92	3	187.00	215.60					

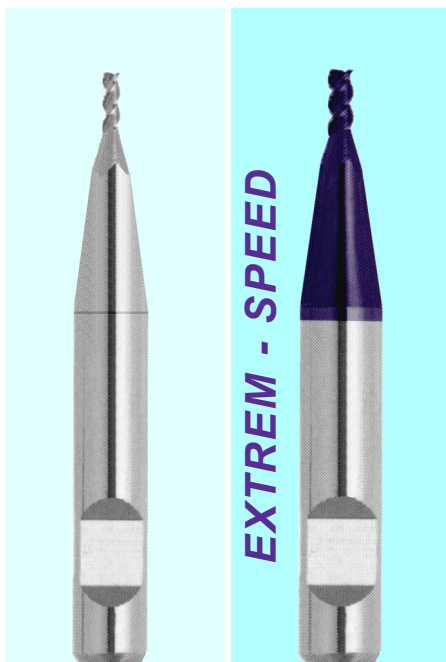

4030 W

4030 WB



4040
4040 W

4040 B
4040 WB Lange Ausführung

4050
4050 W

4050 B *EXTREM - SPEED*
4050 WB beschichtet



4040

4040 B



4040 W

4040 WB



Lange Ausführung

4050 W

4050 WB

4050

4050 B

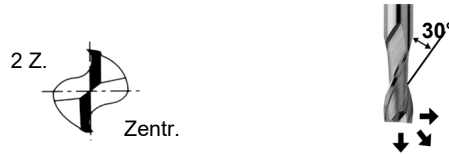

Typ
N

- Universal einsetzbar für sämtliche Werkstoffe sowie zum Fräsen von Keilnuten in Passung P9.
- Mit diesem neuen **VHM - Ultra Fine - Fräser** wird eine wesentlich grössere Zerspanungsleistung möglich.
- Höchstleistung mit **EXTREM - SPEED - Beschichtung**.



Best.-Nr.	Alu	Alu Guss > 10% Si	Stahl < 750N	Stahl < 900N	Stahl < 1400N	Stahl < 55HRC	Stahl < 60HRC	Stahl < 67HRC	INOX	Ti + Cu	SG (G)	Uni-versal	4040 4040 W	4040 B 4040WB	4050 4050 W	4050 B 4050WB
	○	●	●	●	●	●	●	●	●	●	●	●	4040 4040W	4040B 4040WB	4050 4050W	4050B 4050WB
Ø e ₈	Schneid-länge		Schaft-Ø		Gesamt-länge		Z									
..0300	3	4	6	50	2	15.40	20.90	—	—							
..0300	3	7	6	57	2	—	—	18.70	23.10							
..0350	3.5	4	6	50	2	18.70	23.10	—	—							
..0380	3.8	8	6	57	2	—	—	22.00	26.40							
..0400	4	5	6	54	2	15.40	20.90	—	—							
..0400	4	8	6	57	2	—	—	18.70	23.10							
..0450	4.5	5	6	54	2	18.70	23.10	—	—							
..0480	4.8	10	6	57	2	—	—	22.00	27.50							
..0500	5	6	6	54	2	15.40	20.90	—	—							
..0500	5	10	6	57	2	—	—	18.70	24.20							
..0550	5.5	7	6	54	2	18.70	24.20	—	—							
..0575	5.75	10	6	57	2	—	—	22.00	27.50							
..0600	6	7	6	54	2	16.50	20.90	—	—							
..0600	6	10	6	57	2	—	—	18.70	24.20							
..0650	6.5	8	8	58	2	31.90	37.40	—	—							
..0675	6.75	13	8	63	2	—	—	27.50	34.10							
..0700	7	8	8	58	2	28.60	35.20	—	—							
..0750	7.5	9	8	58	2	31.90	37.40	—	—							
..0750	7.75	16	8	63	2	—	—	27.50	34.10							
..0800	8	9	8	58	2	22.00	27.50	—	—							
..0800	8	16	8	63	2	—	—	24.20	30.80							
..0850	8.5	10	10	66	2	37.40	50.60	—	—							
..0870	8.7	16	10	72	2	—	—	37.40	50.60							
..0900	9	10	10	66	2	35.20	48.40	—	—							
..0950	9.5	11	10	66	2	37.40	50.60	—	—							
..0950	9.7	19	10	72	2	—	—	37.40	50.60							
..1000	10	12	10	66	2	31.90	45.10	—	—							
..1000	10	19	10	72	2	—	—	34.10	47.30							
..1000	10.5	12	12	70	2	58.30	71.50	—	—							
..1100	11	12	12	70	2	56.10	72.60	—	—							
..1150	11.5	12	12	73	2	56.10	74.80	—	—							
..1150	11.75	22	12	83	2	—	—	51.70	67.10							
..1200	12	12	12	73	2	45.10	59.40	—	—							
..1200	12	22	12	83	2	—	—	48.40	62.70							
..1370	13.7	14	14	75	2	—	—	84.-	107.80							
..1400	14	14	14	83	2	84.70	101.20	—	—							
..1400	14	22	14	83	2	—	—	88.00	104.50							
..1400	15.7	26	16	92	2	—	—	99.00	117.70							
..1600	16	16	16	82	2	81.40	110.00	—	—							
..1600	16	26	16	92	2	—	—	96.80	115.50							
..1800	18	18	18	84	2	118.80	166.10	—	—							
..1800	18	18	26	92	2	—	—	168.30	191.40							
..1800	20	20	20	92	2	152.90	201.30	—	—							
..2000	20	32	20	104	2	—	—	179.30	207.90							

VHM Schaftfräser

4055

4055 B

4055 W

4055 WB

EXTREM - SPEED
beschichtet

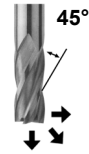

Typ
N

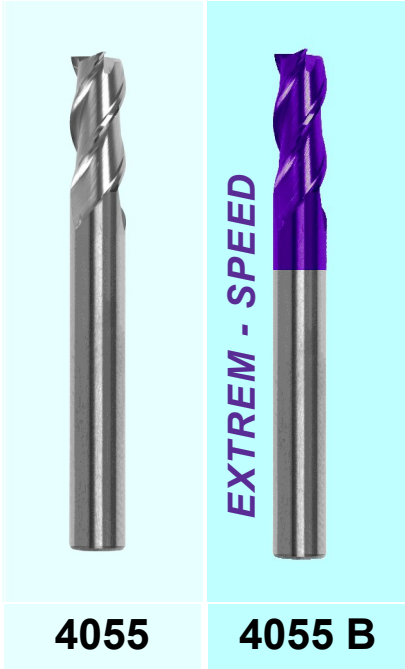

4055

4055 B

- Universal einsetzbar für sämtliche Werkstoffe.
- Mit diesem neuen **VHM - Ultra Fine - Fräser** wird eine wesentlich grössere Zerspanungsleistung möglich.
- Höchstleistung mit **EXTREM - SPEED - Beschichtung**.



Best.-Nr. 4055... 4055w... 4055b... 4055wb...	Alu	Alu Guss > 10% Si	Stahl < 750N	Stahl < 900N	Stahl < 1400N	Stahl < 55HRC	Stahl < 60HRC	Stahl < 67HRC	INOX	Ti > 850N	GG (G)	Uni- versal	4055 4055 W	4055 B 4055 WB
	○	●	●	●	●	●	●	●	●	●	○	●		
	Ø e ₈	Schneid- länge		Schaft- Ø		Gesamt- länge		Z	4055		4055 B			
									4055W		4055WB			
..0300	3	7		6		57		3	16.50		22.00			
..0350	3.5	7		6		57		3	23.10		27.50			
..0400	4	8		6		57		3	16.50		22.00			
..0450	4.5	8		6		57		3	23.10		27.50			
..0500	5	10		6		57		3	16.50		22.00			
..0600	6	10		6		57		3	16.50		22.00			
..0700	7	13		8		63		3	25.30		31.90			
..0800	8	16		8		63		3	23.10		28.60			
..0900	9	16		10		72		3	34.10		46.20			
..1000	10	19		10		72		3	31.90		44.00			
..1200	12	22		12		83		3	45.10		59.40			
..1400	14	22		14		83		3	70.40		85.80			
..1600	16	26		16		92		3	94.60		113.30			
..1800	18	26		18		92		3	128.70		151.80			
..2000	20	32		20		104		3	161.70		193.60			



4055 W

4055 WB

**Europe
force**

VHM Schafffräser kurz

4060

4060 B

4060 W

4060 WB

EXTREM - SPEED

beschichtet

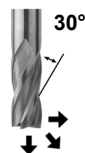

Typ
N

- Universal einsetzbar für sämtliche Werkstoffe.
- Mit diesem neuen **VHM - Ultra Fine - Fräser** wird eine wesentlich grössere Zerspanungsleistung möglich.
- Höchstleistung mit **EXTREM - SPEED - Beschichtung**.



4060

4060 B



4060 W

4060 WB

Best.-Nr. 4060... 4060w... 4060b... 4060wb...	Alu	Alu Guss > 10% Si	Stahl < 750N	Stahl < 900N	Stahl < 1400N	Stahl < 55HRC	Stahl < 60HRC	Stahl < 67HRC	INOX	Ti + Cu	GG (G)	Uni- versal	4060 4060 W	4060 B 4060 WB
	Ø e ₈	Schneid- länge	Schaft- Ø	Gesamt- länge	Z	4060	4060 B							
..0300	3	5	6	50	4	17.50	22.00							
..0350	3.5	6	6	50	4	20.90	25.30							
..0400	4	8	6	54	4	17.50	22.00							
..0450	4.5	8	6	54	4	20.90	25.30							
..0500	5	9	6	54	4	18.70	22.00							
..0550	5.5	10	6	54	4	20.90	26.40							
..0600	6	10	6	54	4	18.70	23.10							
..0650	6.5	11	8	58	4	34.10	39.60							
..0700	7	11	8	58	4	28.60	35.20							
..0800	8	12	8	58	4	23.10	28.60							
..0900	9	13	10	66	4	35.20	44.00							
..1000	10	14	10	66	4	31.90	39.60							
..1200	12	16	12	73	4	46.20	58.30							
..1400	14	18	14	75	4	74.80	86.90							
..1600	16	22	16	82	4	94.60	112.20							
..1800	18	24	18	84	4	128.70	148.50							
..2000	20	26	20	92	4	167.20	196.90							

Europe
force

VHM Schaftfräser

4070

4070 B

4070 W

4070 WB

EXTREM - SPEED
beschichtet

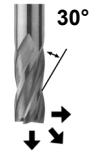

Typ
N



4070

4070 B

- Universal einsetzbar für sämtliche Werkstoffe.
- Mit diesem neuen **VHM - Ultra Fine - Fräser** wird eine wesentlich grössere Zerspanungsleistung möglich.
- Höchstleistung mit **EXTREM - SPEED - Beschichtung**.



4070 W

4070WB

Best.-Nr. 4070... 4070w... 4070b... 4070wb...	Alu	Alu Guss > 10% Si	Stahl < 750N	Stahl < 900N	Stahl < 1400N	Stahl < 55HRC	Stahl < 60HRC	Stahl < 67HRC	INOX	Ti > 850N	GG (G)	Uni- versal	4070 4070 W	4070 B 4070 WB					
	○	●	●	●	●	●	●	●	●	●	●	●	Ø e ₈	Schneid- länge	Schaft- Ø	Gesamt- länge	Z	4070	4070 B
..0300													Ø 3	8	6	57	4	18.70	23.10
..0400													Ø 4	11	6	57	4	18.70	23.10
..0450													Ø 4.5	11	6	57	4	23.10	27.50
..0500													Ø 5	13	6	57	4	19.80	25.20
..0600													Ø 6	13	6	57	4	19.80	25.20
..0700													Ø 7	16	8	63	4	30.80	37.40
..0800													Ø 8	19	8	63	4	23.10	28.60
..0900													Ø 9	19	10	72	4	35.20	47.30
..1000													Ø 10	22	10	72	4	35.20	47.30
..1200													Ø 12	26	12	83	4	50.60	64.90
..1400													Ø 14	26	14	83	4	77.00	93.50
..1600													Ø 16	32	16	92	4	97.90	117.70
..1800													Ø 18	32	18	92	4	135.30	158.40
..2000													Ø 20	38	20	104	4	173.80	205.70

**Europe
force**

VHM Schafffräser extra lang

4080

4080 B

4080 WB

4080 WB

EXTREM - SPEED
beschichtet

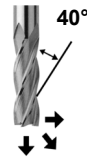
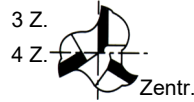

Typ
N



- Universal einsetzbar für sämtliche Werkstoffe, speziell für Arbeiten an tiefliegenden und schwer erreichbaren Stellen.
- Mit diesem neuen **VHM - Ultra Fine - Fräser** wird eine wesentlich grössere Zerspanungsleistung möglich.
- Höchstleistung mit **EXTREM - SPEED - Beschichtung**.



	Alu Guss > 10% Si	Stahl < 750N	Stahl < 900N	Stahl < 1400N	Stahl < 55HRC	Stahl < 60HRC	Stahl < 67HRC	INOX	Ti > 850	GG (G)	Uni- versal	4080 4080W	4080 B 4080WB
Best.-Nr. 4080... 4080w... 4080b... 4080wb...	Ø h ₁₀	Schneid- länge	Schaft- Ø	Gesamt- länge	Z	4080		4060 B					
						4080W		4060WB					
..0600	6	25	6	75	3	39.60		46.20					
..0800	8	25	8	75	3	59.40		66.00					
..1000	10	38	10	100	3	83.60		95.70					
..1200	12	50	12	100	4	116.60		139.70					
..1600	16	75	16	150	4	239.80		266.20					
..2000	20	75	20	150	4	397.10		437.80					
..2500	25	75	25	150	4	542.30		591.80					

Europe
force

4090

4090 B

4090 W

4090 WB *EXTREM - SPEED*
beschichtet



EXTREM - SPEED

4090

4090 B



EXTREM - SPEED

4090 W

4090 WB



EXTREM - SPEED

4091 W

4091 B

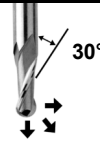

Typ
N

- Universal einsetzbar für sämtliche Werkstoffe, vorwiegend für Werkzeug- und Formenbau.
- Mit diesem neuen **VHM - Ultra Fine - Fräser** wird eine wesentlich grössere Zerspanungsleistung möglich.
- Höchstleistung mit **EXTREM - SPEED - Beschichtung**.
- Auch geeignet zum **Hochgeschwindigkeitsfräsen**.



Best.-Nr. 4090... 4090b... 4090w... 4090wb...	Alu	Alu Guss > 10% Si	Stahl < 750N	Stahl < 900N	Stahl < 1400N	Stahl < 55HRC	Stahl < 60HRC	Stahl < 67HRC	INOX	Ti + Cu	GG (G)	Uni- versal	4090 4090 W	4090 B 4090 WB
	○	●	●	●	●	●	●	●	●	●	●	●		
	Ø h ₁₀	Schneid- länge	Schaft- Ø	Gesamt- länge	Z									
..0050	0.5	1.5	3	39	2	19.80		24.20						
..0100	1	3	3	38	2	16.50		22.00						
..0150	1.5	5	3	38	2	15.40		20.90						
..0200	2	7	3	38	2	14.30		19.80						
..0250	2.5	7	3	38	2	14.30		19.80						
..0300	3	9	3	38	2	14.30		19.80						
..0350	3.5	12	4	50	2	19.80		25.30						
..0400	4	14	4	50	2	14.30		19.80						
..0450	4.5	14	5	50	2	18.70		23.10						
..0500	5	16	5	50	2	15.40		20.90						
..0600	6	19	6	50	2	16.50		23.10						
..0700	7	19	8	63	2	26.40		33.00						
..0800	8	21	8	63	2	23.10		28.60						
..0900	9	22	10	75	2	40.70		55.00						
..1000	10	22	10	75	2	35.20		46.20						
..1100	11	25	11	75	2	50.60		63.80						
..1200	12	25	12	75	2	56.10		69.30						
..1400	14	30	14	89	2	86.90		106.70						
..1600	16	32	16	89	2	111.10		128.70						
..1800	18	35	18	100	2	159.50		190.30						
..2000	20	38	20	100	2	195.80		232.10						

Kurz

Best.-Nr.
4091...
4091b...
4091w...
4091wb...

4091
4091 W

4091 B
4091 WB

					4091		4091 B		
	Ø	L	Ø	L	Ø	L	Ø	L	
..0200	2	3	6	50	2	18.70	22.00		
..0250	2.5	4	6	50	2	18.70	22.00		
..0300	3	4	6	50	2	18.70	22.00		
..0350	3.5	5	6	54	2	19.80	23.10		
..0400	4	5	6	54	2	19.70	23.10		
..0450	4.5	6	6	54	2	19.70	23.10		
..0500	5	6	6	54	2	19.70	23.10		
..0600	6	7	6	54	2	19.70	23.10		

VHM Radiusfräser

HSC + 3 D

4095

4095 B

4095 W

4095 WB

EXTREM - SPEED

beschichtet

4 Z.



Typ
N

- Universal einsetzbar für sämtliche Werkstoffe, vorwiegend für Werkzeug- und Formenbau.
- Mit diesem neuen VHM - **Ultra Fine** - Fräser wird eine wesentlich grössere Zerspanungsleistung möglich.
- Höchstleistung mit **EXTREM - SPEED** - Beschichtung.
- Auch geeignet zum **Hochgeschwindigkeitsfräsen**.

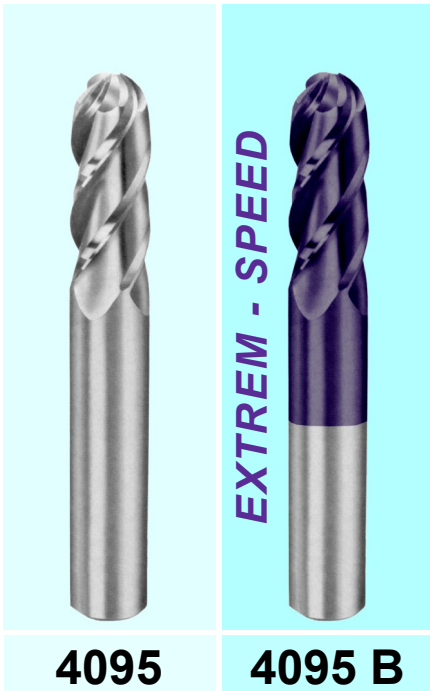

Best.-Nr.
4095...
4095b...
4095w...
4095wb...

	Alu Guss > 10% Si	Stahl < 750N	Stahl < 900N	Stahl < 1400N	Stahl < 55HRC	Stahl < 60HRC	Stahl < 67HRC	INOX	Ti + Cu	GG (G)	Uni- versal	4095 4095 W	4095 B 4095 WB
Ø h ₁₀	○	●	●	●	●	●	●	●	○	●	●		
	Schneid- länge		Schaft- Ø		Gesamt- länge		Z						
..0200	2	7	3	39	4	28.60	34.10						
..0250	2.5	7	3	39	4	28.60	34.10						
..0300	3	9	3	39	4	28.60	34.10						
..0350	3.5	12	4	51	4	34.10	38.50						
..0400	4	14	4	51	4	28.60	35.20						
..0450	4.5	14	5	51	4	35.20	39.60						
..0500	5	16	5	51	4	28.60	35.20						
..0600	6	19	6	64	4	31.90	37.50						
..0700	7	19	8	64	4	45.10	50.60						
..0800	8	21	8	64	4	37.40	46.20						
..0900	9	22	10	70	4	55.00	68.20						
..1000	10	22	10	70	4	55.00	68.20						
..1100	11	25	11	70	4	63.80	77.00						
..1200	12	25	12	76	4	63.80	84.70						
..1400	14	30	14	89	4	110.00	139.70						
..1600	16	32	16	89	4	148.50	172.70						
..1800	18	35	18	102	4	203.50	227.70						
..2000	20	38	20	102	4	261.80	298.10						



5000 B

HPC

5010 B

EXTREM - SPEED
beschichtet

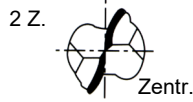
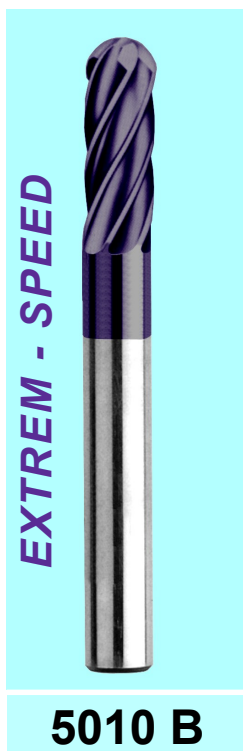
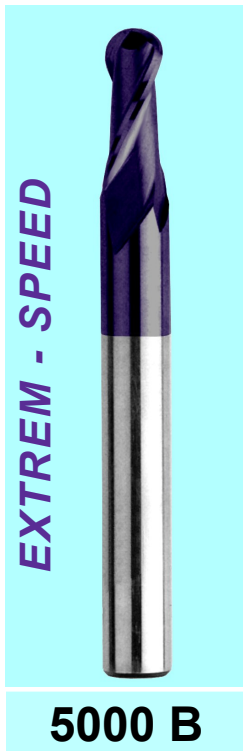

Typ
N

- Speziell entwickeltes Werkzeug für die **Hart-Zerspanung Hard Cutting 45-60 HRC** sowie zum **Hochgeschwindigkeitsfräsen High Speed**.
- Mit diesem neuen **VHM - Ultra Fine - Fräser** wird eine um wesentlich grössere Zerspanungsleistung möglich.
- Höchstleistung mit **EXTREM - SPEED - Beschichtung**.

Best.-Nr. 5000b... 5010b...	Ø e ₈	Schneid- länge	Schaft- Ø	Gesamt- länge	Z	5000 B		5010 B	
						5000 B	5010 B	5000 B	5010 B
..0100	1	3	6	50	2	47.30	--		
..0150	1.5	4	6	50	2	47.30	--		
..0200	2	5	6	50	2	47.30	--		
..0200	2	5	6	50	4	--	47.30		
..0300	3	8	6	70	2	47.30	--		
..0300	3	8	6	70	4	--	47.30		
..0400	4	8	6	70	2	47.30	--		
..0400	4	8	6	70	4	--	47.30		
..0500	5	12	6	80	2	58.30	--		
..0500	5	10	6	80	4	--	49.50		
..0600	6	12	6	90	2	58.30	--		
..0600	6	12	6	90	4	--	52.80		
..0700	7	14	8	90	2	86.90	--		
..0700	7	14	8	90	4	--	74.80		
..0800	8	14	8	100	2	86.90	--		
..0800	8	14	8	100	4	--	74.80		
..0900	9	18	10	100	2	107.80	--		
..0900	9	18	10	100	4	--	115.50		
..1000	10	18	10	100	2	107.80	--		
..1000	10	18	10	100	4	--	115.50		
..1200	12	22	12	110	2	122.10	--		
..1200	12	22	12	110	4	--	151.80		
..1400	14	26	14	110	2	210.10	--		
..1400	14	26	14	110	4	--	216.70		
..1600	16	30	16	140	2	317.90	--		
..1600	16	30	16	140	4	--	317.90		
..1800	18	34	18	140	2	396.00	--		
..1800	18	34	18	140	4	--	445.50		
..2000	20	38	20	160	2	486.20	--		
..2000	20	38	20	160	4	--	499.40		

VHM Kugelkopffräser lang

High Speed + Hard Cutting 45-60 HRC + 3 D

5012 B

EXTREM - SPEED
beschichtet

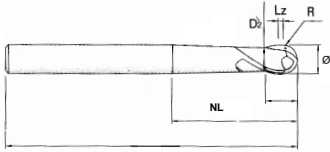

2 Z.



4 Z.



Ø 6-16

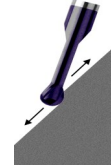

Typ
N

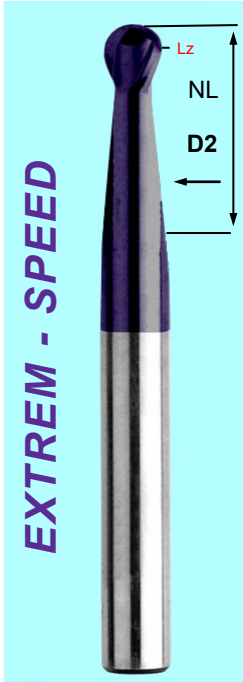

5012 B

- Speziell entwickeltes Werkzeug für die **Hart-Zerspanung Hard Cutting 45-60 HRC** sowie zum **Hochgeschwindigkeitsfräsen High Speed**.
- Mit diesem neuen **VHM - Ultra Fine - Fräser** wird eine wesentlich grössere Zerspanungsleistung möglich.
- Höchstleistung mit **EXTREM - SPEED - Beschichtung**.



Best.-Nr. 5012b...	Alu	Alu Guss > 10% Si	Stahl < 750N	Stahl < 900N	Stahl < 1400N	Stahl < 55HRC	Stahl < 60HRC	Stahl < 67HRC	INOX	Ti + Cu	GG (G)	Uni- versal	5012 B
	Ø e ₈	R	Schaft- länge	Ø D2 NL= Nutzlänge	Schaft- Ø	Lz	Gesamt- länge	Z	5012 B				
..0300	3	1.5	4	2.5 x 30	6	1,5	80	2	44.00				
..0400	4	2.0	5	3.3 x 30	6	1,5	80	2	44.00				
..0500	5	2.5	6	4.1 x 43	6	2	80	2	44.00				
..0600	6	3.0	7	4.7 x 30	6	2	100	4	82.50				
..0800	8	4.0	9	6.5 x 36	8	3	100	4	86.90				
..1000	10	5.0	11	8.2 x 43	10	3	100	4	113.30				
..1200	12	6.0	13	9.8 x 52	12	3	100	4	151.80				
..1600	16	8.0	15	13.4 x 61	16	3	150	4	300.30				

5013 B

VHM-Kugelkopffräser lang

ohne LZ

EXTREM - SPEED
beschichtet

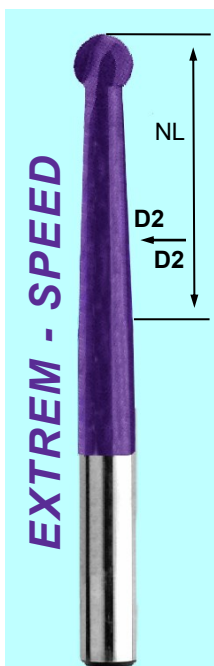

5013 B

2 Z.



4 Z.



Ø 6-16

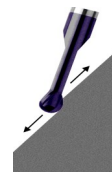

Typ
N



Best.-Nr. 5013b...	Alu	Alu Guss > 10% Si	Stahl < 750N	Stahl < 900N	Stahl < 1400N	Stahl < 55HRC	Stahl < 60HRC	Stahl < 67HRC	INOX	Ti + Cu	GG (G)	Uni- versal	5013 B
	Ø e ₈	R	Schaft- länge	Ø D2 NL= Nutzlänge	Schaft- Ø	Gesamt- länge	Z	5013 B					
..0300	3	1.5	2.3	2.5 x 30	6	80	2	62.70					
..0400	4	2.0	3.1	3.3 x 30	6	80	2	62.70					
..0500	5	2.5	3.9	4.1 x 38	6	80	2	62.70					
..0600	6	3.0	4.9	4.7 x 30	6	100	4	77.00					
..0800	8	4.0	6.3	6.5 x 33	8	100	4	86.90					
..1000	10	5.0	7.9	8.2 x 40	10	100	4	116.60					
..1200	12	6.0	9.5	9.8 x 49	12	100	4	143.00					
..1600	16	8.0	12.4	13.4 x 59	16	150	4	258.50					

5015 B

EXTREM - SPEED

beschichtet

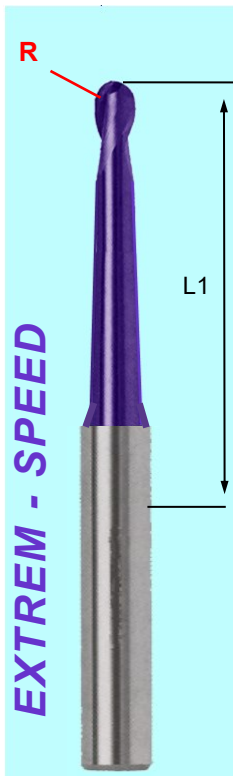

EXTREM - SPEED

5015 B

2 Z.

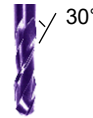

Typ
N

- Speziell entwickeltes Werkzeug für die **Hart-Zerspanung Hard Cutting 45-70 HRC** sowie zum **Hochgeschwindigkeitsfräsen High Speed**.
- Mit diesem neuen **VHM - Ultra Fine - Fräser** wird eine wesentlich grössere Zerspanungsleistung möglich.
- Höchstleistung mit **EXTREM - SPEED - Beschichtung**.



Best.-Nr. 5015b...	Alu	Alu Guss > 10% Si	Stahl < 750N	Stahl < 900N	Stahl < 1400N	Stahl < 55HRC	Stahl < 60HRC	Stahl < 67HRC	INOX	Ti + Cu	GG (G)	Uni- versal	5015 B
	Ø h ₁₀	Radius	Schneid- länge		L1	Schaft- Ø	Ges.- länge	5015 B					
..0200	2	1.0	3	63	6	110	47.30						
..0300	3	1.5	5	65	6	110	47.30						
..0400	4	2.0	7	67	6	110	47.30						
..0500	5	2.5	10	70	6	110	50.60						
..0600	6	3.0	18	78	10	155	92.40						
..0800	8	4.0	30	100	12	155	118.80						
..1000	10	5.0	40	100	12	155	128.70						
..1200	12	6.0	50	110	16	155	203.50						

VHM Torusfräser

Hard Cutting 45-70 HRC

5017 B

EXTREM - SPEED
beschichtet

5017 WB

EXTREM - SPEED
beschichtet

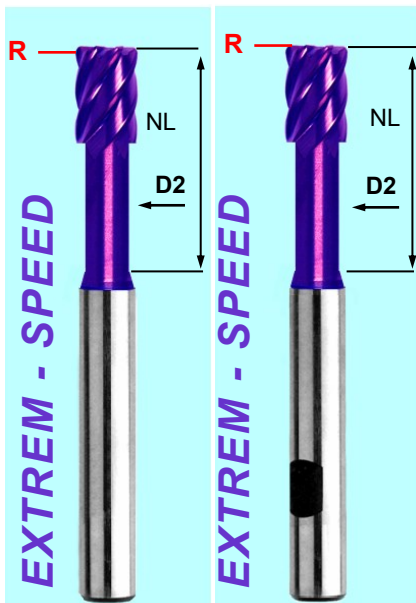

EXTREM - SPEED

5017 B

EXTREM - SPEED

5017 WB

- Speziell entwickeltes Werkzeug für die **Hart-Zerspanung Hard Cutting 45-70 HRC** sowie zum **Hochgeschwindigkeitsfräsen High Speed**. Einsatz auch im Formen - und Werkzeugbau.
- Mit diesem neuen **VHM - Ultra Fine - Fräser** wird eine wesentlich grössere Zerspanungsleistung möglich.
- Höchstleistung mit **EXTREM - SPEED - Beschichtung**.



Best.-Nr. 5017b... 5017wb...	Alu	Alu Guss > 10% Si	Stahl < 750N	Stahl < 900N	Stahl < 1400N	Stahl < 55HRC	Stahl < 60HRC	Stahl < 67HRC	INOX	Ti + Cu	GG (G)	Uni- versal	5017 B 5017 WB
	Ø h ₁₀	Radius	Schneid- länge		Ø D2 NL= Nutzlänge	Schaft- Ø	Ges.- länge	5017 B 5017 WB					
..060003	6	0.3	6	5.8 x 14	6	50	49.50						
..060005	6	0.5	6	5.8 x 14	6	50	49.50						
..080005	8	0.5	8	7.8 x 24	8	60	56.10						
..080010	8	1.0	8	7.8 x 24	8	60	56.10						
..100005	10	0.5	10	9.8 x 30	10	70	83.60						
..100010	10	1.0	10	9.8 x 30	10	70	83.60						
..120005	12	0.5	12	11.8 x 30	12	75	118.80						
..120010	12	1.0	12	11.8 x 30	12	75	118.80						
..160010	16	1.0	16	15 x 44	16	92	215.60						

5020 B **5020 WB** *EXTREM - SPEED*
beschichtet

5030 B *EXTREM - SPEED*
beschichtet

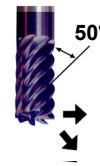

Typ
N

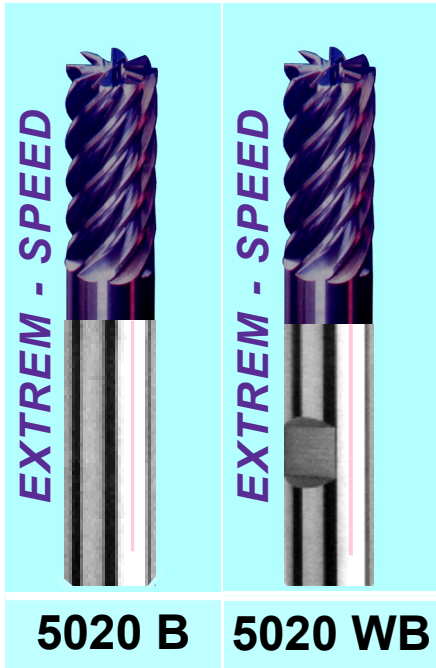

- Speziell entwickeltes Werkzeug für die **Hard-Zerspanung Hard Cutting 45-70 HRC** sowie zum **Hochgeschwindigkeitsfräsen High Speed**.
- Mit diesem neuen **VHM - Ultra Fine - Fräser** wird eine wesentlich grössere Zerspanungsleistung möglich.
- Höchstleistung mit **EXTREM - SPEED - Beschichtung**.

Best.-Nr. 5020b... 5020wb...	Alu	Alu Guss > 10% Si	Stahl < 750N	Stahl < 900N	Stahl < 1400	Stahl < 55HR	Stahl < 60HR	Stahl < 67HR	INOX	Ti + Cu	GG (G)	Uni- versal	5020 B 5020 WB	
	Ø h ₁₀	Schneid- länge	Schaft- Ø	Ges.- länge	Z	5020 B		5020 WB						
..0600	6	13	6	57	6	42.90								
..0800	8	19	8	63	6	68.20								
..1000	10	22	10	72	6	83.60								
..1200	12	26	12	83	6	118.80								
..1600	16	32	16	92	6	204.60								
..2000	20	38	20	104	8	288.20								

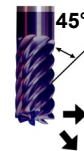

Typ
N

- **lange Ausführung**

Best.-Nr. 5030b...	Alu	Alu Guss > 10% Si	Stahl < 750N	Stahl < 900N	Stahl < 1400N	Stahl < 55HR	Stahl < 60HR	Stahl < 67HR	INOX	Ti + Cu	GG (G)	Uni- versal	5030 B	
	Ø h ₁₀	Schneid- länge	Schaft- Ø	Ges.- länge	Z	5030 B								
..0600	6	18	6	62	6	52.80								
..0800	8	24	8	68	6	58.30								
..1000	10	30	10	80	6	95.70								
..1200	12	36	12	93	6	140.80								
..1600	16	48	16	108	6	239.80								
..2000	20	60	20	125	8	336.60								

5035 B

5035 WB

EXTREM - SPEED
beschichtet



Typ
N

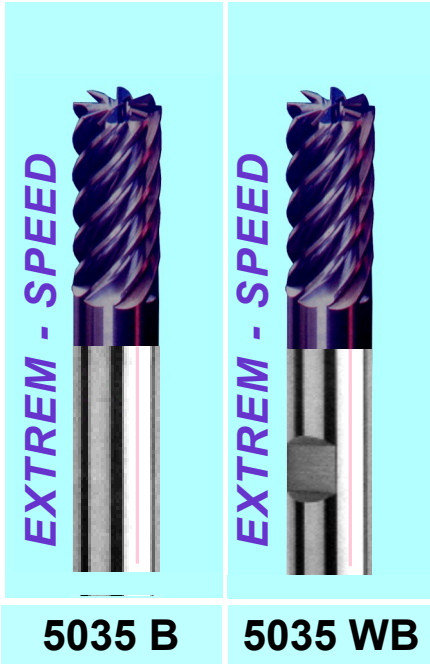

- Extra preiswerter Vielzahn VHM-Schaftfräser
- Hervorragende Oberflächengüte (Superfinish) beim Umfangfräsen von schwer zerspanbaren Stählen.
- Mit diesem neuen **VHM - Ultra Fine - Fräser** wird eine um wesentlich grössere Zerspanungsleistung möglich.
- Höchstleistung mit **EXTREM - SPEED - Beschichtung**.

Best.-Nr. 5035b... 5035wb...	Alu	Alu Guss > 10% Si	Stahl < 750N	Stahl < 900N	Stahl < 1400N	Stahl < 55HRC	Stahl < 60HRC	Stahl < 67HR	INOX	Ti + Cu	GG (G)	Uni- versal	5035 B	5035 WB
	○	○	●	●	○	○	○	○	○	○	○	○	5035	5035 W
	Ø h ₁₀	Schneid- länge		Schaft- Ø		Ges.- länge		Z						
..0600	6	8		6		39		6					19.80	
..0800	8	11		8		43		6					28.60	
..1000	10	13		10		50		6					39.60	
..1200	12	15		12		55		6					51.70	
..1600	16	18		16		62		6					83.60	
..2000	20	22		20		75		8					155.10	

VHM Schlichtfräser mit abgesetztem Schaft

5038

5038 B

5038 W

5038 WB

EXTREM - SPEED
beschichtet

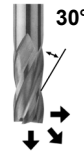

Typ
N



- VHM - Fräser mit abgesetztem Schaft

Best.-Nr. 5038... 5038b... 5038w... 5038wb...	Alu	Alu Guss > 10% Si	Stahl < 750N	Stahl < 900N	Stahl < 1400N	Stahl < 55HRC	Stahl < 60HRC	Stahl < 67HR	INOX	Ti + Cu	GG (G)	Uni- versal	5038	5038 B	5038 W	5038 WB
	○	○	●	●	○	○	○	○	○	○	○	○	5038	5038 B	5038 W	5038 WB
	Ø h ₁₀	Schneid- länge		Schaft- Ø		Ges.- länge		Z								
..0600	6	10		4		54		3					16.50	24.20		
..0700	7	12		4		58		3					20.90	35.20		
..0800	8	12		6		58		3					20.90	35.20		
..0900	9	12		6		66		3					31.90	51.70		
..1000	10	12		6		66		3					31.90	49.50		
..1200	12	14		8		73		4					42.90	63.80		

VHM Schafffräser High-Speed

HSC + Superfinish

5040 B **5040 WB** *EXTREM - SPEED*
beschichtet

5041 B *EXTREM - SPEED*
beschichtet

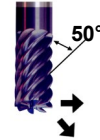

Typ
N

- Hervorragende Oberflächengüte (Superfinish) beim Umfangfräsen von schwer zerspanbaren Stählen.
- Mit diesem neuen **VHM - Ultra Fine - Fräser** wird eine wesentlich grössere Zerspanungsleistung möglich.
- Höchstleistung mit **EXTREM - SPEED - Beschichtung**.
- Auch geeignet zum **Hochgeschwindigkeitsfräsen**.

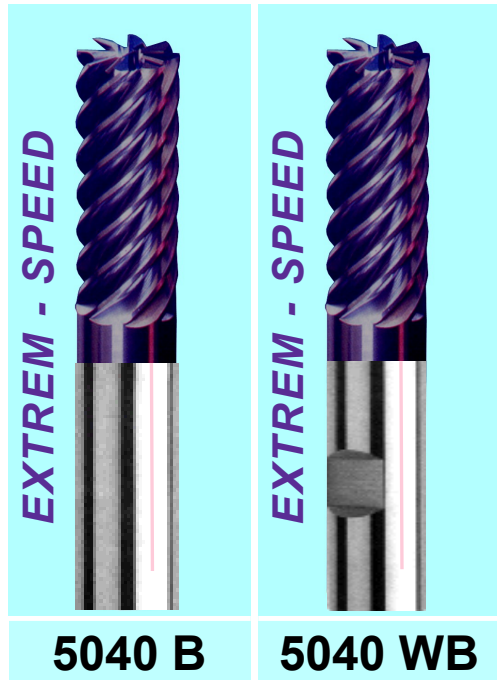

Best.-Nr. 5040b... 5040wb...	Alu	Alu Guss > 10% Si	Stahl < 750N	Stahl < 900N	Stahl < 1400N	Stahl < 55HRC	Stahl < 60HRC	Stahl < 67HRC	INOX < 900N	INOX > 900N	Ti + Cu	GG (G)	Uni- versal	5040 B 5040 WB
	○	●	●	●	●	○	○	○	○	○	○	●	●	5040 B 5040 WB
	Ø h ₁₀	Schneid- länge		Schaft- Ø		Ges.- länge		Z		5040 B 5040 WB				
..0600	6	13	6	57	6	35.20								
..0700	7	16	8	63	6	42.90								
..0800	8	19	8	63	6	42.90								
..0900	9	19	10	72	6	70.40								
..1000	10	22	10	72	6	70.40								
..1200	12	26	12	83	6	84.70								
..1400	14	26	14	83	6	122.10								
..1600	16	32	16	92	6	156.20								
..1800	18	32	18	92	8	253.00								
..2000	20	38	20	104	8	260.70								



**Europe
force** HSC

Best.-Nr. 5041b...	Alu	Alu Guss > 10% Si	Stahl < 750N	Stahl < 900N	Stahl < 1400N	Stahl < 55HRC	Stahl < 60HRC	Stahl < 67HRC	INOX < 900N	INOX > 900N	Ti + Cu	GG (G)	Uni- versal	5041 B
	○	●	●	●	●	○	○	○	○	○	○	●	●	5041 B
	Ø h ₁₀	Schneid- länge		Schaft- Ø		Ges.- länge		Z		5041 B				
..0600	6	26	6	70	6	49.50								
..0800	8	36	8	90	6	75.90								
..1000	10	46	10	100	6	107.80								
..1200	12	56	12	110	6	128.70								
..1600	16	66	16	130	6	316.80								
..2000	20	76	20	140	6	578.60								

VHM Schaftfräser im Probeset

Im Probeset 10 % günstiger

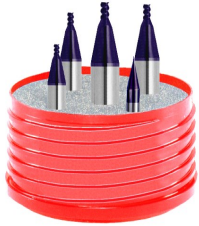

Art.-Nr. 6150
VHM MINI-Fräser
2 3 4 5 6
3 Zähne **EXTREM - SPEED**
Fr. 75.90



Art.-Nr. 6180
VHM High Speed Fräser
Ø 6 8 10 12 16
EXTREM - SPEED
Fr. 201.30

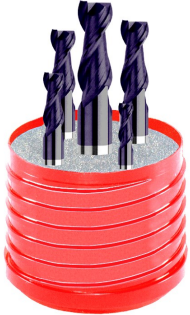

Art.-Nr. 6160
VHM Schaftfräser für ALU
Ø 6 8 10 12 16
2 Zähne **EXTREM - SPEED - ALU**
Fr. 270.60



Art.-Nr. 6190
VHM Feinschrupppräser
Ø 6 8 10 12 16
EXTREM - SPEED
Fr. 321.20



Art.-Nr. 6170
VHM Schaftfräser
Ø 6 8 10 12 16
4 Zähne **EXTREM - SPEED**
Fr. 236.50

VHM Schruppfräser

5043 B

5043 WB

EXTREM - SPEED
beschichtet

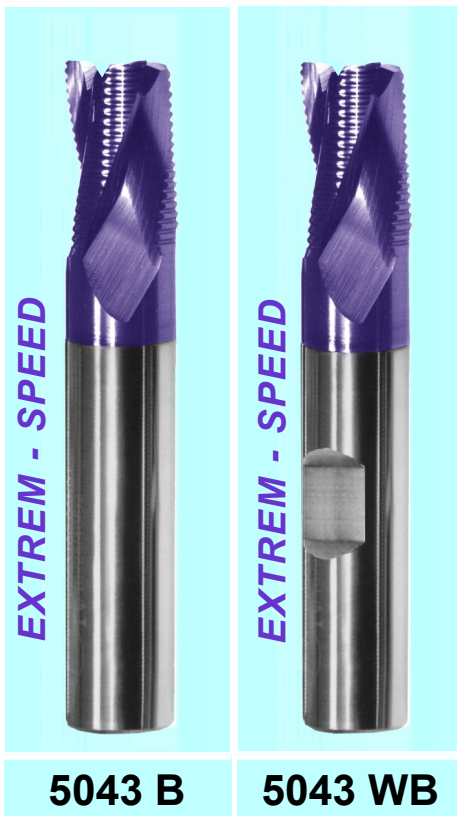

HÖCHSTLEISTUNG

- bohren und fräsen mit **einem Werkzeug**
- 50% Zeiteinsparung

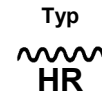
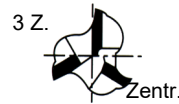

Best.-Nr.
5043b...
5043wb...

	Alu	Alu Guss > 10% Si	Stahl < 750N	Stahl < 900N	Stahl < 1400N	Stahl < 55HRC	Stahl < 60HRC	Stahl < 67HRC	INOX	Ti > 850N	GG (G)	Uni- versal	5043 B	5043 WB
	○	●	●	●	●	○	○	○	●	○	●	●		
	Ø	Schneid- länge	Nutz- länge	Schaft- Ø	Gesamt- länge	Z							5043 B	5043 WB
..0600	6	9	15	6	57	3							47.30	
..0800	8	12	20	8	63	3							59.40	
..1000	10	15	25	10	72	3							74.80	
..1200	12	18	30	12	83	3							88.00	
..1400	14	21	35	14	83	3							195.80	
..1600	16	24	40	16	92	3							225.50	
..2000	20	30	50	20	104	3							294.80	

VHM Schlichtfräser lang mit Schruppfunktion

5045 B

5045 WB

EXTREM - SPEED
beschichtet

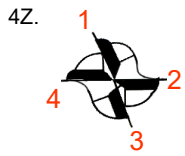

ungleiche Zahn-Teilung + verschiedene Drallwinkel

Typ

Best.-Nr.
5045b...
5045wb...

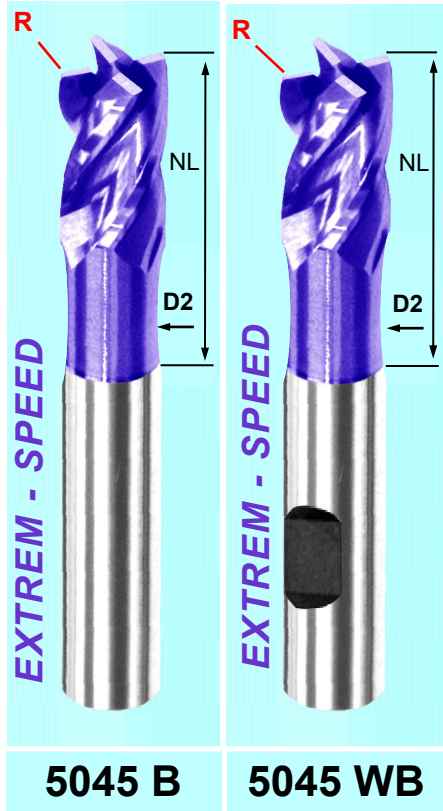

HÖCHSTLEISTUNG

- einstechen und nuten
- schruppen und schlichten mit einem Werkzeug

5048 B

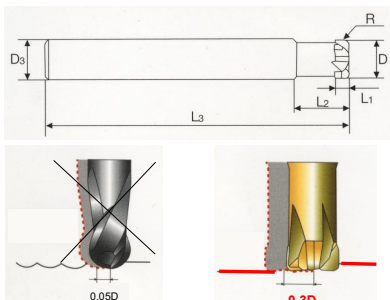

Hochvorschub Fräser

HPC

	Alu Guss > 10% Si	Stahl < 750N	Stahl 900N	Stahl < 1400	Stahl < 55HRC	Stahl < 60HRC	Stahl < 67HRC	INOX	Ti > 850N	GG (G)	Uni- versal	5045 B 5045 WB
	Ø e ₈	R	Schneid- länge	Ø D2 NL= Nutzlänge	Schaft- Ø	Gesamt- länge	Z					
..0400	4	-	5	3.8 x 9	6	45	4					
..040001	4	0.1	5	3.8 x 9	6	45	4					
..040003	4	0.3	5	3.8 x 12	6	55	4					
..040005	4	0.5	5	3.8 x 12	6	55	4					
..040010	4	1.0	5	3.8 x 12	6	55	4					
..0600	6	-	7	5.8 x 14	6	50	4					
..060002	6	0.2	7	5.8 x 14	6	50	4					
..060005	6	0.5	7	5.8 x 20	6	60	4					
..060010	6	1.0	7	5.8 x 20	6	60	4					
..060015	6	1.5	7	5.8 x 20	6	60	4					
..0800	8	-	9	7.8 x 18	8	60	4					
..080002	8	0.2	9	7.8 x 18	8	60	4					
..080005	8	0.5	9	7.8 x 25	8	60	4					
..080010	8	1.0	9	7.8 x 25	8	60	4					
..080015	8	1.5	9	7.8 x 25	8	60	4					
..080020	8	2.0	9	7.8 x 25	8	60	4					
..1000	10	-	12	9.7 x 25	10	75	4					
..100002	10	0.2	12	9.7 x 25	10	75	4					
..100005	10	0.5	11	9.7 x 32	10	75	4					
..100010	10	1.0	11	9.7 x 32	10	75	4					
..100015	10	1.5	11	9.7 x 32	10	75	4					
..100020	10	2.0	11	9.7 x 32	10	75	4					
..1200	12	-	15	11.7 x 30	12	75	4					
..120003	12	0.3	15	11.7 x 30	12	75	4					
..120005	12	0.5	12	11.7 x 38	12	75	4					
..120010	12	1.0	12	11.7 x 38	12	75	4					
..120015	12	1.5	12	11.7 x 38	12	75	4					
..120020	12	2.0	12	11.7 x 38	12	75	4					
..1600	16	-	32	15.0 x 44	16	90	4					
..160003	16	0.3	32	15.0 x 44	16	90	4					
..160015	16	1.5	32	15.0 x 44	16	90	4					
..160020	16	2.0	32	15.0 x 44	16	90	4					
..2000	20	-	38	19.0 x 55	20	100	4					
..200003	20	0.3	38	19.0 x 55	20	100	4					
..200015	20	1.5	38	19.0 x 55	20	100	4					
..200020	20	2.0	38	19.0 x 55	20	100	4					

5048 B

Best.-Nr.
5048b...

	D	R	L1	L2	L3	D3	Z	Preis
..030005	3	0.5	1.2	8	50	6	4	47.30
..040005	4	0.5	1.5	10	50	6	4	47.30
..060005	6	0.5	2.5	12	60	6	4	57.20
..060010	6	1.0	2.5	12	60	6	4	57.20
..080010	8	1.0	3.5	16	60	8	4	68.20
..080020	8	2.0	3.5	16	60	8	4	68.20
..100010	10	1.0	4	20	70	10	4	84.70
..100020	10	2.0	4	20	70	10	4	84.70
..120020	12	2.0	5	25	80	12	4	115.50
..120030	12	3.0	5	25	80	12	4	115.50
..160020	16	2.0	7	32	100	16	4	201.30
..160030	16	3.0	7	32	100	16	4	201.30

VHM -Schruppfräser

HPC

5049 B

EXTREM - SPEED

beschichtet



5049 B

Höchstleistung



Typ
N

- Bis zu **50%** höhere Zerspanungsleistung
- Dank extra tiefen Spanräumen und 50% Drallwinkel können Sie mit diesem Fräser schruppen und schlichten in **einem Arbeitsgang**

Best.-Nr. 5049b...	5049 B									
	Ø	K 45°	Schneidlänge	Schaft-Ø	Ges.-länge	Z				
..0600	6	0.15	16	6	64	4				
..0800	8	0.20	20	8	64	4				
..1000	10	0.20	22	10	70	4				
..1200	12	0.25	25	12	78	4				
..1600	16	0.25	35	16	89	4				
..2000	20	0.50	40	20	102	4				

VHM XNF Schruppfräser

HPC+ High-Speed

5050 WB

EXTREM - SPEED

beschichtet

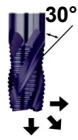
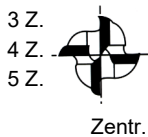

Typ



- Mit diesem neu entwickelten **Hochleistungswerkzeug mit XNF-Profil** senken Sie Ihre Stückkosten um **mindestens 30%**. Die Vorschubgeschwindigkeit kann verdoppelt werden; trotzdem erhalten Sie eine **saubere Werkstückoberfläche** (siehe Grafik unten).
- Mit diesem neuen **VHM - Ultra Fine - Fräser** wird eine wesentlich grössere Zerspanungsleistung möglich.
- Höchstleistung mit **EXTREM - SPEED - Beschichtung**.
- Auch geeignet zum **Hochgeschwindigkeitsfräsen**, einsetzbar bis **60 HRC**.



5050 WB

NEU
XNF - Profil

Best.-Nr. 5050wb...	5050 WB									
	Ø h ₁₀	Schneidlänge	Schaft-Ø	Ges.-länge	Z					
..0400	4	8	6	57	3					
..0600	6	13	6	57	3					
..0800	8	19	8	63	3					
..1000	10	22	10	72	4					
..1200	12	26	12	83	4					
..1400	14	26	14	83	4					
..1600	16	32	16	92	4					
..1800	18	32	18	92	4					
..2000	20	38	20	104	4					
..2500	25	45	25	121	5					
..3000	30	45	25	121	5					

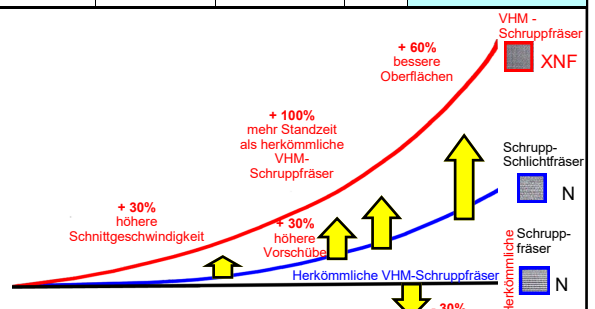

5055 WB

EXTREM - SPEED
beschichtet



EXTREM - SPEED

5055 WB



High - Flyer

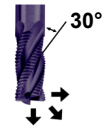

Typ
HR

- **Universal einsetzbar** für alle Werkstoffe.

Best.-Nr. 5055wb...	Alu	Alu Guss	Stahl < 750N	Stahl < 900N	Stahl < 1400N	Stahl < 55HRC	Stahl < 60HRC	Stahl < 67HRC	INOX	Ti + Cu	GG (G)	Uni- versal	5055 WB
	○	●	●	●	○	○	○	○	○	○	○	○	
Ø _{e8}	Schneid- länge		Schaft- Ø		Ges.- länge		Z		5055 WB				
..0600	6	16	6	57	3	34.10							
..0700	7	16	8	63	3	55.00							
..0800	8	16	8	63	3	40.70							
..0900	9	19	10	72	4	82.50							
..1000	10	22	10	72	4	62.70							
..1200	12	26	12	83	4	74.80							
..1400	14	26	14	83	4	140.80							
..1600	16	32	16	92	4	144.10							
..1800	18	32	18	92	4	192.50							
..2000	20	38	20	104	4	220.00							

VHM Feinschruppfräser

HPC + **EXTREM - SPEED**

5060 WB 5061 WB

EXTREM - SPEED

beschichtet

Höchstleistung

Mit
Innenkühlung

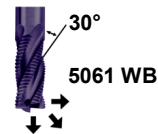
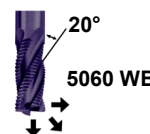

Typ
HR

- Universal einsetzbar in schwer zerspanbaren Werkstoffen mit hoher Zerspanungsleistung.
- Mit diesem neuen **VHM - Ultra Fine - Fräser** wird eine wesentlich grössere Zerspanungsleistung möglich.
- Höchstleistung mit **EXTREM - SPEED - Beschichtung**.

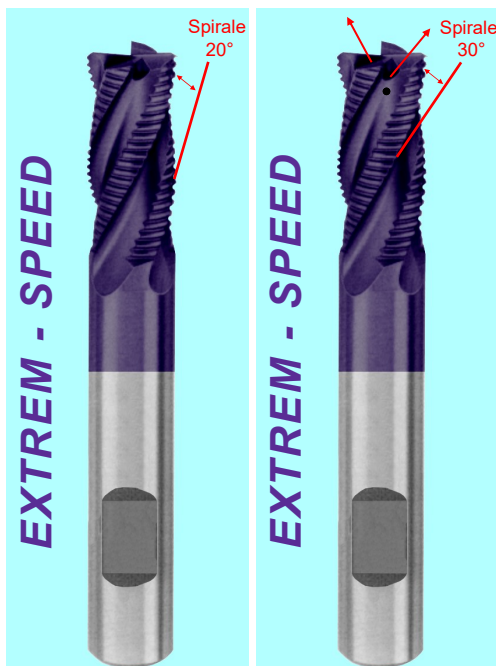

EXTREM - SPEED

5060 WB

EXTREM - SPEED

5061 WB

Best.-Nr. 5060wb... 5061wb...	Alu	Alu Guss > 10% Si	Stahl < 750N	Stahl < 900N	Stahl < 1400N	Stahl < 55HRC	Stahl < 60HRC	Stahl < 67HRC	INOX	Ti + Cu	GG (G)	Uni- versal	5060 WB	5061 WB
	○	●	●	●	○	○	○	○	○	○	○	○	5060 WB	5061 WB
Ø _{e8}	Schneid- länge		Schaft- Ø		Ges.- länge		Z		5060 WB		5061 WB			
..0600	6	16	6	57	3	55.00	118.80							
..0700	7	16	8	63	3	83.60	-							
..0800	8	16	8	63	3	66.00	135.30							
..0900	9	19	10	72	4	101.20	-							
..1000	10	22	10	72	4	81.40	137.50							
..1200	12	26	12	83	4	111.10	147.80							
..1400	14	26	14	83	4	165.00	-							
..1600	16	32	16	92	4	195.80	256.30							
..1800	18	32	18	92	4	239.80	-							
..2000	20	38	20	104	4	256.30	360.80							

5062 B

5062 WB

EXTREM - SPEED

beschichtet

4 Z.
5 Z.
6 Z.



Typ
HR

Höchstleistung



- Speziell entwickeltes Werkzeug für das Hochgeschwindigkeitsfräsen High Speed
- Mit diesem neuen VHM - Ultra Fine - Fräser wird eine wesentlich grössere Zerspanungsleistung möglich.
- Höchstleistung mit EXTREM - SPEED - Beschichtung.



Best.-Nr. 5062b... 5062wb...	Alu	Alu Guss > 10% Si	Stahl < 750N	Stahl < 900N	Stahl < 1400N	Stahl < 55HRC	Stahl < 60HRC	Stahl < 67HRC	INOX < 900N	INOX > 900N	Ti + Cu	GG (G)	Uni- versal	5062 B 5062 WB
	○	●	●	●	●	●	●	●	●	○	○	○	○	
	Ø h ₁₀	Schneid- länge	Schaft- Ø	Gesamt- länge	Z									
..0600	6	7	6	54	4									52.80
..0800	8	9	8	58	4									68.20
..1000	10	14	10	66	4									83.60
..1200	12	16	12	73	4									106.70
..1600	16	22	16	82	5									253.00
..2000	20	26	20	92	6									333.30

VHM - Feinschruppfräser lang

5065 B

5065 WB

EXTREM - SPEED

beschichtet

4 Z.
5 Z.
6 Z.



Typ
HR

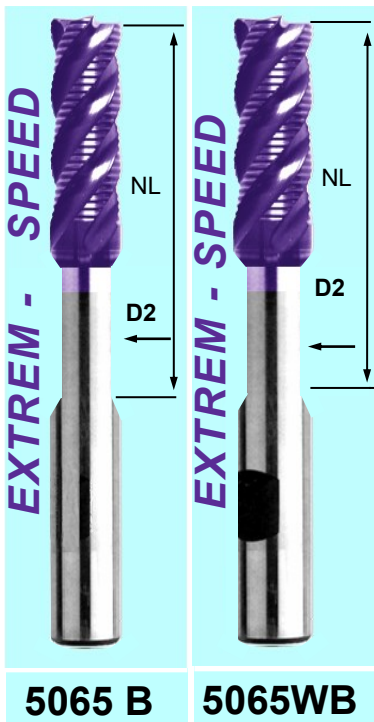

- lange Ausführung
- gleiche Eigenschaften wie oben aufgeführt
- mit hinterschlifftem Schaft
- grössere Nutzlänge



Best.-Nr. 5065b... 5065wb...	Alu	Alu Guss > 10% Si	Stahl < 750N	Stahl < 900N	Stahl < 1400N	Stahl < 55HRC	Stahl < 60HRC	Stahl < 67HRC	INOX	Ti + Cu	GG (G)	Uni- versal	5065 B 5065 WB
	○	●	●	●	●	●	●	●	●	○	○	○	
	Ø e ₈	Schneid- länge	Ø D2 NL= Nutzlänge	Schaft- Ø	Gesamt- länge	Z							
..0600	6	16	5.5 x 20	6	57	4							58.30
..0800	8	16	7.5 x 26	8	63	4							71.50
..1000	10	22	9.5 x 31	10	72	4							104.50
..1200	12	26	11.5x37	12	83	4							125.40
..1600	16	32	15.5x51	16	100	5							282.70
..2000	20	38	19.2x59	20	110	6							372.90

VHM Schafffräser X-TREME lang

mit Eckenradius HSC + 3 D

5080 B

HPC

5080 WB

EXTREM - SPEED
beschichtet

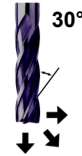

Typ
N

Europe
force

- Universal einsetzbar für sämtliche Werkstoffe, speziell für Werkzeug- und Formenbau;
3-D-Bearbeitung auf 3- oder 5-Achsenmaschinen.
- Mit diesem neuen **VHM-Ultra Fine**-Fräser wird eine wesentlich grössere Zerspanungsleistung möglich.
- Höchstleistung mit **EXTREM - SPEED - Beschichtung**.
- Auch geeignet zum **Hochgeschwindigkeitsfräsen**.



Best.-Nr. 5080D... 5080WB...	Alu	Alu Guss > 10% Si	Stahl < 750N	Stahl < 900N	Stahl < 1400N	Stahl < 55HRC	Stahl < 60HRC	Stahl < 67HRC	INOX	Ti + Cu	GG (G)	Uni- ver- sal	5080 B 5080 WB
	Ø e ₈	Radius	Schneid- länge	Schaft- Ø	Ges.- länge	Z							
..060005	6	0.5	15	6	55	4	34.10						
..060010	6	1.0	15	6	55	4	34.10						
..080005	8	0.5	20	8	65	4	42.90						
..080010	8	1.0	20	8	65	4	42.90						
..080015	8	1.5	20	8	65	4	42.90						
..080020	8	2.0	20	8	65	4	42.90						
..100005	10	0.5	25	10	80	4	56.10						
..100010	10	1.0	25	10	80	4	56.10						
..100015	10	1.5	25	10	80	4	56.10						
..100020	10	2.0	25	10	80	4	56.10						
..100025	10	2.5	25	10	80	4	56.10						
..100030	10	3.0	25	10	80	4	56.10						
..120005	12	0.5	30	12	82	4	74.80						
..120010	12	1.0	30	12	82	4	74.80						
..120015	12	1.5	30	12	82	4	74.80						
..120020	12	2.0	30	12	82	4	74.80						
..120025	12	2.5	30	12	82	4	74.80						
..120030	12	3.0	30	12	82	4	74.80						
..160005	16	0.5	40	16	100	4	167.20						
..160010	16	1.0	40	16	100	4	167.20						
..160015	16	1.5	40	16	100	4	167.20						
..160020	16	2.0	40	16	100	4	167.20						
..160030	16	3.0	40	16	100	4	167.20						
..200005	20	0.5	45	20	110	4	261.80						
..200010	20	1.0	45	20	110	4	261.80						
..200015	20	1.5	45	20	110	4	261.80						
..200020	20	2.0	45	20	110	4	261.80						
..200030	20	3.0	45	20	110	4	261.80						

VHM Torusfräser lang

mit Eckenradius HSC + 3 D



5090 B HPC

5090 WB

EXTREM - SPEED
beschichtet



Typ
N



- Universal einsetzbar für sämtliche Werkstoffe, speziell für Werkzeug- und Formenbau; 3-D-Bearbeitung auf 3- oder 5-Achsenmaschinen.
- Mit diesem neuen **VHM - Ultra Fine - Fräser** wird eine wesentlich grössere Zerspanungsleistung möglich.
- Höchstleistung mit **EXTREM - SPEED - Beschichtung**.
- Auch geeignet zum **Hochgeschwindigkeitsfräsen**.

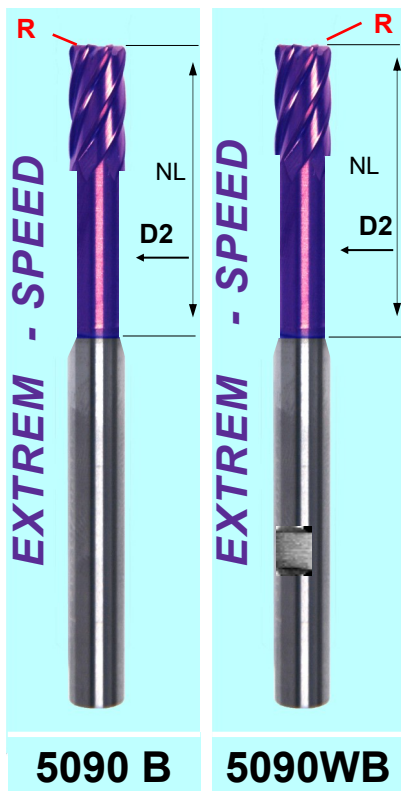

Best.-Nr.
5090b...
5090wb...

	Alu Guss > 10% Si	Stahl < 750N	Stahl < 900N	Stahl < 1400N	Stahl < 55HRC	Stahl < 60HRC	Stahl < 67HRC	INOX	Ti + Cu	GG (G)	Uni- versal	5090 B 5090 WB	
	○	●	●	●	○	○	○	●	○	●	●		
Ø e ₈	Radius	Schneid- länge	Ø D2 NL= Nutzlänge	Schaft- Ø	Ges.- länge	Z							
..030002	3	0.2	8	2.5 x 22	6	60	4	44.00					
..030005	3	0.5	8	2.5 x 22	6	60	4	44.00					
..040002	4	0.2	11	3.3 x 30	6	70	4	44.00					
..040005	4	0.5	11	3.3 x 30	6	70	4	44.00					
..040010	4	1.0	11	3.3 x 30	6	70	4	44.00					
..050002	5	0.2	13	4.1 x 40	6	80	4	50.60					
..050005	5	0.5	13	4.1 x 40	6	80	4	50.60					
..050010	5	1.0	13	4.1 x 40	6	80	4	50.60					
..060002	6	0.2	13	4.7 x 40	6	90	4	58.30					
..060005	6	0.5	13	4.7 x 40	6	90	4	58.30					
..060010	6	1.0	13	4.7 x 40	6	90	4	58.30					
..080005	8	0.5	19	6.5 x 46	8	100	4	68.20					
..080010	8	1.0	19	6.5 x 46	8	100	4	68.20					
..080015	8	1.5	19	6.5 x 46	8	100	4	68.20					
..080020	8	2.0	19	6.5 x 46	8	100	4	68.20					
..100005	10	0.5	22	8.2 x 46	10	100	4	83.60					
..100010	10	1.0	22	8.2 x 46	10	100	4	83.60					
..100015	10	1.5	22	8.2 x 46	10	100	4	83.60					
..100020	10	2.0	22	8.2 x 46	10	100	4	83.60					
..100025	10	2.5	22	8.2 x 46	10	100	4	83.60					
..120005	12	0.5	26	9.8 x 52	12	110	4	107.80					
..120010	12	1.0	26	9.8 x 52	12	110	4	107.80					
..120015	12	1.5	26	9.8 x 52	12	110	4	107.80					
..120020	12	2.0	26	9.8 x 52	12	110	4	107.80					
..120025	12	2.5	26	9.8 x 52	12	110	4	107.80					
..120030	12	3.0	26	9.8 x 52	12	110	4	107.80					

6000

6000 B

EXTREM - SPEED
beschichtet

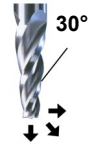

Typ
N

- Universal einsetzbar für sämtliche Werkstoffe im Werkzeug- und Formenbau.
- Mit diesem neuen **VHM - Ultra Fine - Fräser** wird eine wesentlich grössere Zerspanungsleistung möglich.
- Höchstleistung mit **EXTREM - SPEED - Beschichtung**.
- Auch geeignet zum **Hochgeschwindigkeitsfräsen**.



Best.-Nr. 6000... 6000b...	Material										6000	6000 B
	Alu	Alu Guss > 10% Si	Stahl < 750N	Stahl < 900N	Stahl < 1400N	Stahl < 55HRC	Stahl < 60HRC	Stahl < 67HRC	INOX	Ti + Cu		
	Winkel pro Seite	Stirn- Ø	Schneid- länge	Schaft- Ø	Ges.- länge	Z						
..0400050100	0.5°	1	8	4	45	4	6000		6000 B			
..0400100100	1°	1	8	4	45	4	39.60		45.10			
..0400150100	1.5°	1	8	4	45	4	39.60		45.10			
..0400200100	2°	1	8	4	45	4	39.60		45.10			
..0400050150	0.5°	1.5	8	4	45	4	39.60		45.10			
..0400100150	1°	1.5	8	4	45	4	39.60		45.10			
..0400150150	1.5°	1.5	8	4	45	4	39.60		45.10			
..0400200150	2°	1.5	8	4	45	4	39.60		45.10			
..0600050300	0.5°	3	15	6	57	3	56.10		62.70			
..0600100300	1°	3	15	6	57	3	56.10		62.70			
..0600150300	1.5°	3	15	6	57	3	56.10		62.70			
..0600200300	2°	3	15	6	57	3	56.10		62.70			
..0600300300	3°	3	15	6	57	3	56.10		62.70			
..0600500300	5°	3	17	6	57	3	56.10		62.70			
..0800050500	0.5°	5	25	8	63	3	60.50		67.10			
..0800100500	1°	5	25	8	63	3	60.50		67.10			
..0800150500	1.5°	5	25	8	63	3	60.50		67.10			
..0800200500	2°	5	25	8	63	3	60.50		67.10			
..0800300500	3°	5	25	8	63	3	60.50		67.10			
..0800500500	5°	5	17	8	63	3	60.50		67.10			
..1000050500	0.5°	5	35	10	72	3	71.50		84.70			
..1000100500	1°	5	35	10	72	3	71.50		84.70			
..1000150500	1.5°	5	35	10	72	3	71.50		84.70			
..1000500600	5	6	23	10	72	3	71.50		84.70			
..1200200800	2°	8	40	12	83	3	92.40		110.00			
..1200250800	2.5°	8	40	12	83	3	92.40		110.00			
..1200300800	3°	8	35	12	83	3	92.40		110.00			
..1200400800	4°	8	29	12	83	3	92.40		110.00			
..1200500800	5°	8	23	12	83	3	92.40		110.00			
..1600201200	2°	12	50	16	92	3	188.10		207.90			
..1600251200	2.5°	12	46	16	92	3	188.10		207.90			
..1600301200	3°	12	38	16	92	3	188.10		207.90			
..1600401200	4°	12	23	16	92	3	188.10		207.90			
..1600501200	5°	12	23	16	92	3	188.10		207.90			

6010

6010 B

EXTREM - SPEED
beschichtet



6010



6010 B



Typ
N

- Universal einsetzbar für sämtliche Werkstoffe im Werkzeug- und Formenbau.
- Höchstleistung mit **EXTREM - SPEED - Beschichtung**.
- Auch geeignet zum **Hochgeschwindigkeitsfräsen**.
- mit abgesetztem Schaft für tiefere Nuten (Zuschlag 24.-)



Best.-Nr.
6010...
6010B...

Alu	Alu Guss > 10% Si	Stahl < 750N	Stahl < 900N	Stahl < 1400N	Stahl < 55HRC	Stahl < 60HRC	Stahl < 67HRC	INOX	Ti + Cu	GG (G)	Uni- versal	6010	6010 B
Winkel pro Seite	Radius	Stirn- Ø	Schneid- länge	Schaft- Ø	Ges.- länge	Z	6010	6010 B					
..040010050100	1°	0.5	1	8	4	45	4	45.10	49.50				
..040015050100	1.5°	0.5	1	8	4	45	4	45.10	49.50				
..040020050100	2°	0.5	1	8	4	45	4	45.10	49.50				
..040010100200	1°	1.0	2	8	4	45	4	45.10	49.50				
..040015100200	1.5°	1.0	2	8	4	45	4	45.10	49.50				
..040020100200	2°	1.0	2	8	4	45	4	45.10	49.50				
..060005150300	0,5°	1.5	3	15	6	57	3	60.50	64.90				
..060010150300	1°	1.5	3	15	6	57	3	60.50	64.90				
..060015150300	1.5°	1.5	3	15	6	57	3	60.50	64.90				
..060020150300	2°	1.5	3	15	6	57	3	60.50	64.90				
..060030150300	3°	1.5	3	15	6	57	3	60.50	64.90				
..060050150300	5°	1.5	3	17	6	57	3	60.50	64.90				
..080005250500	0.5°	2.5	5	25	8	63	3	71.50	75.90				
..080010250500	1°	2.5	5	25	8	63	3	71.50	75.90				
..080015250500	1.5°	2.5	5	25	8	63	3	71.50	75.90				
..080020250500	2°	2.5	5	25	8	63	3	71.50	75.90				
..080030250500	3°	2.5	5	25	8	63	3	71.50	75.90				
..080050250500	5°	2.5	5	17	8	63	3	71.50	75.90				
..100005250500	0.5°	2.5	5	35	10	72	3	80.30	91.30				
..100010250500	1°	2.5	5	35	10	72	3	80.30	91.30				
..100015250500	1.5°	2.5	5	35	10	72	3	80.30	91.30				
..100050300600	5	3	6	23	10	72	3	80.30	91.30				
..120020400800	2°	4	8	40	12	83	3	107.80	123.20				
..120025400800	2.5°	4	8	40	12	83	3	107.80	123.20				
..120030400800	3°	4	8	35	12	83	3	107.80	123.20				
..120040400800	4°	4	8	29	12	83	3	107.80	123.20				
..120050400800	5°	4	8	23	12	83	3	107.80	143.00				
..160020601200	2°	6	12	50	16	92	3	214.50	234.30				
..160025601200	2.5°	6	12	46	16	92	3	214.50	234.30				
..160030601200	3°	6	12	38	16	92	3	214.50	234.30				
..160040601200	4°	6	12	23	16	92	3	214.50	234.30				
..160050601200	5°	6	12	23	16	92	3	214.50	234.30				

6015 90°

6015 B 90° *EXTREM - SPEED* beschichtet

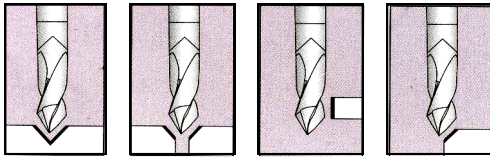

- Zum Anfasen und Entgraten, Senken und Nutenfräsen mit einem Werkzeug.
- Spitze 90°
- Mit diesem neuen **VHM - Ultra Fine - Fräser** wird eine wesentlich grössere Zerspanungsleistung möglich.
- Höchstleistung mit **EXTREM - SPEED - Beschichtung**.
- Auch geeignet zum **Hochgeschwindigkeitsfräsen**.

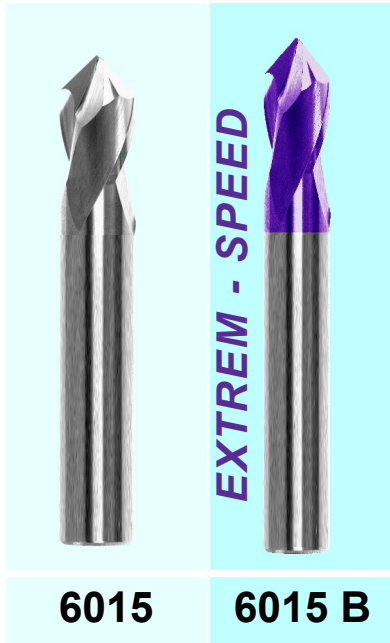

Best.-Nr. 6015... 6015b...	Alu	Alu	Stahl	Stahl	Stahl	Stahl	Stahl	Stahl	INOX	Ti	GG	Uni-	6015	6015 B
	Guss	> 10% Si	< 750N	< 900N	< 1400N	< 55HRC	< 60HRC	< 67HRC		+ Cu	(G)	versal		
	Ø	Schaft-	Schaft-	Ges.-	Z	6015		6015 B						
	h ₁₁	länge	Ø	länge										
..0300	3	6	4	50	2	36.30		69.30						
..0400	4	8	5	50	2	36.30		69.30						
..0500	5	10	6	50	2	36.30		69.30						
..0600	6	12	8	58	2	36.30		69.30						
..0800	8	16	10	70	2	73.50		118.80						
..1000	10	18	12	90	2	94.00		132.00						
..1200	12	20	12	90	2	98.00		172.70						
..1600	16	26	16	92	2	173.00		354.20						

VHM Entgrater

6016 B 90°

6017 B 60° *EXTREM - SPEED* beschichtet



- Zum Anfasen und Entgraten von Werkstückkanten.
- Mit diesem neuen **VHM - Ultra Fine - Fräser** wird eine wesentlich grössere Zerspanungsleistung möglich.
- Höchstleistung mit **EXTREM - SPEED - Beschichtung**.
- Auch geeignet zum **Hochgeschwindigkeitsfräsen**.



Best.-Nr. 6016B... 6017B...	Alu	Alu	Stahl	Stahl	Stahl	Stahl	Stahl	Stahl	INOX	Ti	GG	Uni-	6016 B 90°	6017 B 60°
	Guss	> 10% Si	< 750N	< 900N	< 1400N	< 55HRC	< 60HRC	< 67HRC		+ Cu	(G)	versal		
	Ø	Schaft-	Ges.-	Z	6016 B 90°		6017 B 60°							
	h ₁₁	Ø	länge											
..0400	4	4	50	4	24.20		36.30							
..0600	6	6	57	4	30.80		45.10							
..0800	8	8	63	5	36.30		52.80							
..1000	10	10	72	5	47.30		71.50							
..1200	12	12	83	5	71.50		105.60							
..1400	14	14	100	5	140.80		210.10							
..1600	16	16	100	5	154.00		231.00							
..1800	18	18	100	6	198.00		299.20							
..2000	20	20	100	6	243.10		364.10							

VHM Vor- und Rückwärtsentgrater

6018 B

EXTREM - SPEED

beschichtet

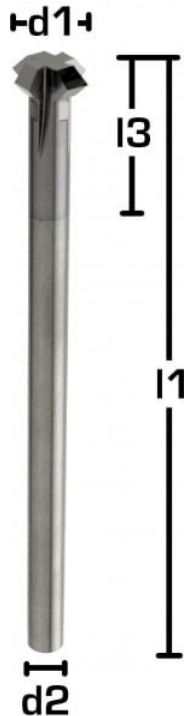

6018B

- Beidseitig 45°. Zum Vor- und Rückwärtsentgraten oder zum Anfasen mit einem Werkzeug !

Best.-Nr. 6018b...	Alu	Alu Guss > 10% Si	Stahl < 750N	Stahl < 900N	Stahl < 1400N	Stahl < 55HRC	Stahl < 60HRC	Stahl < 67HRC	INOX	Ti + Cu	GG (G)	Uni- versal	6018 B
	○	●	●	●	●	○	○	○	●	○	●	●	
	Ø	Ø Hals und L3	Schaft- D2 Ø		Ges.- länge	Z							
..0400	4	2.0 x 12	6		100	4	6018 B						
..0600	6	4 x 18	6		100	4	75.90						
..0800	8		6		100	4	80.30						
..1000	10		6		100	4	105.60						
..1200	12		6		100	4	127.60						
..1600	16		10		100	4	149.60						
							210.10						

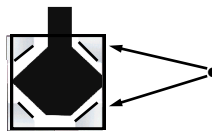

oben und unten, beidseitig anfasen mit einem Werkzeug und in einer Aufspannung !



VHM Radius - Vor- und Rückwärtsentgrater

6019 B

EXTREM - SPEED

beschichtet



6019 B

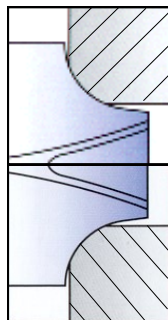

- Beidseitig zum Vor- und Rückwärtsentgraten sowie zum **Kanten abrunden**.

Best.-Nr. 6019B...	Alu	Alu Guss > 10% Si	Stahl < 750N	Stahl < 900N	Stahl < 1400N	Stahl < 55HRC	Stahl < 60HRC	Stahl < 67HRC	INOX	Ti + Cu	GG (G)	Uni- versal	6019 B
	○	●	●	●	●	○	○	○	●	○	●	●	
	Radius	Ø	d2	Schaft- Ø	Ges.- länge	Z							
..080002	0.2	8	7.6	6	100	4	6019 B						
..080003	0.3	8	7.4	6	100	4	195.80						
..080004	0.4	8	7.2	6	100	4	195.80						
..080005	0.5	8	5	6	100	4	202.40						
..100008	0.8	10	8.4	6	100	4	206.80						
..100010	1.0	10	8	6	100	4	206.80						
..100012	1.2	10	7.6	6	100	4	213.40						
..100015	1.5	10	7	6	100	4	213.40						

VHM Viertelkreisfräser

6025 BR

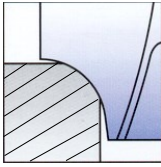

- Zum Abrunden von Kanten und Konturen an schwer zugänglichen Stellen.
- Höchstleistung - Beschichtung für schwerzerspanbare und rostfreie Stähle.
- Schaftausführung DIN 6335 HB

Alu	Alu Guss >	Stahl < 750N	Stahl < 900N	Stahl < 1400N	Stahl < 55HRC	Stahl < 60HRC	Stahl < 67HRC	INOX	Ti + Cu	GG (G)	Uni- versal
○	●	●	●	●	●	●	●	●	○	●	●



Best.-Nr. 60251br...	R	Ø	d2 Ø	Schaft- Ø(h6)	Ges.- länge	Z	Preis
..0020	0.20	6	5.6	6	60	4	25.70
..0030	0.30	6	5.4	6	60	4	25.70
..0040	0.40	6	5.2	6	60	4	25.70
..0050	0.50	8	7.0	8	70	4	46.40
..0060	0.60	8	6.8	8	70	4	46.40
..0075	0.75	8	6.5	8	70	4	46.40
..0080	0.80	8	6.4	8	70	4	46.40
..0100	1.00	8	6	8	70	4	62.20
..0150	1.50	10	7	10	75	4	62.20
..0200	2.00	10	6.0	10	75	4	62.20
..0250	2.50	12	7.0	12	75	4	86.70
..0300	3.00	12	6.0	12	75	4	86.70
..0400	4.00	16	8.0	16	80	4	162.90
..0500	5.00	20	10.0	16	80	4	216.50

VHM Viertelkreisfräser

60251 BR

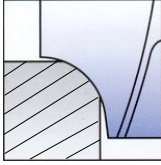

- Zum Abrunden von Kanten und Konturen an schwer zugänglichen Stellen.
- Höchstleistung - Beschichtung für schwerzerspanbare und rostfreie Stähle.
- Schaftausführung DIN 6335 HB

Alu	Alu Guss >	Stahl < 750N	Stahl < 900N	Stahl < 1400N	Stahl < 55HRC	Stahl < 60HRC	Stahl < 67HRC	INOX	Ti + Cu	GG (G)	Uni- versal
○	●	●	●	●	●	●	●	●	○	●	●



Best.-Nr. 60251br...	R	Ø	d2 Ø	Schaft- Ø(h6)	Ges.- länge	Z	Preis
..0025	0.20	6	5.6	6	60	4	25.70
..0030	0.30	6	5.4	6	60	4	25.70
..0040	0.40	6	5.2	6	60	4	25.70
..0050	0.50	8	7.0	8	70	4	46.40
..0060	0.60	8	6.8	8	70	4	46.40
..0075	0.75	8	6.5	8	70	4	46.40
..0080	0.80	8	6.4	8	70	4	46.40
..0100	1.00	8	6	8	70	4	62.20
..0150	1.50	10	7	10	75	4	62.20
..0200	2.00	10	6.0	10	75	4	62.20
..0250	2.50	12	7.0	12	75	4	86.70
..0300	3.00	12	6.0	12	75	4	86.70
..0400	4.00	16	8.0	16	80	4	162.90
..0500	5.00	20	10.0	16	80	4	216.50

6026 90°
6027 120°
6028 142°

6026 B 90° *EXTREM - SPEED*
6027 B 120°
6028 B 142°
 beschichtet



6026 90°
6027 120°
6028 142°



6026 B 90°
6027 B 120°
6028 B 142°

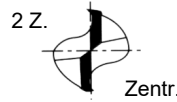

- Zum Zentrieren von genauen Bohrungen, zum Anbohren sowie gleichzeitigem Ansenken, wenn nachher mit kleinerem Ø gebohrt wird.
- Höchstleistung mit **EXTREM - SPEED - Beschichtung**.



Best.-Nr. 6026... 6026b...	Material							6026 90°		6026B 90°		
	Alu Guss > 10% Si	Stahl < 750N	Stahl < 900N	Stahl < 1400N	INOX	GG (G)	Uni-versal	Ø e ₈	Schaft-länge	Ges.-länge	6026 90°	6026 B 90°
..0300	●	●	●	○	●	●	●	3	10	32	19.80	27.50
..0400	●	●	●	○	●	●	●	4	11	40	22.40	33.00
..0600	●	●	●	○	●	●	●	6	13	50	24.20	33.00
..0800	●	●	●	○	●	●	●	8	23	60	34.10	46.20
..1000	●	●	●	○	●	●	●	10	24	70	47.30	62.70
..1200	●	●	●	○	●	●	●	12	24	70	61.60	85.80
..1600	●	●	●	○	●	●	●	16	29	75	118.80	145.20
..2000	●	●	●	○	●	●	●	20	35	100	203.50	264.00

Best.-Nr. 6027... 6027b... 6028... 6028b...	Material							6027 120°		6027 B 120°		6028 142°		6028 B 142°	
	Alu Guss > 10% Si	Stahl < 750N	Stahl < 900N	Stahl < 1400N	INOX	GG (G)	Uni-versal	Ø e ₈	Schaft-länge	Ges.-länge	6027 120°	6027 B 120°	6028 142°	6028 B 142°	
..0300	●	●	●	○	●	●	●	3	10	32	23.10	34.10	23.10	34.10	
..0400	●	●	●	○	●	●	●	4	11	40	27.50	38.50	27.50	38.50	
..0600	●	●	●	○	●	●	●	6	13	50	31.90	42.90	31.90	42.90	
..0800	●	●	●	○	●	●	●	8	23	60	42.90	57.20	42.90	57.20	
..1000	●	●	●	○	●	●	●	10	24	70	59.40	80.30	59.40	80.30	
..1200	●	●	●	○	●	●	●	12	24	70	71.50	96.80	71.50	96.80	
..1600	●	●	●	○	●	●	●	16	29	75	119.90	156.20	119.90	156.20	
..2000	●	●	●	○	●	●	●	20	35	100	203.50	300.30	203.50	300.30	

6031

3 Z.



6031

- Aus **Voll-Hartmetall (aus einem Stück, nicht gelötet)**, dadurch stabiler zum Senken von hochfesten sowie rostfreien Stählen.
- Mit diesem Senker wird eine wesentlich grössere Zerspanungsleistung möglich.
- Höchstleistung mit **MC3 oder TIN - Beschichtung** zum Senken von gehärteten Werkstoffen bis **60 HRC**.



Alu Guss >	Stahl < 750N	Stahl < 900N	Stahl < 55HRC	INOX	GG (G)	Uni-versal	6030 Mit 3 Flächen Anschlag ab 12.4mm					
●	●	●	●	●	●	●	Ø mm	Schaft-Ø	Senk-bereich	Gesamtlänge	Preis	Preis Beschichtet
●	●	●	●	●	●	●	4.30	4	1.5 -4.3	40	57.20	64.90
●	●	●	●	●	●	●	6.30	5	2.0 -6.3	45	64.90	73.70
●	●	●	●	●	●	●	8.30	6	2.5 -8.3	50	77.00	89.10
●	●	●	●	●	●	●	10.40	6	3.0 -10.4	50	85.80	100.10
●	●	●	●	●	●	●	12.40	8	3.0 -12.4	56	101.20	118.80
●	●	●	●	●	●	●	16.50	10	4.0 -16.5	60	117.70	140.80
●	●	●	●	●	●	●	20.50	10	4.0 -20.5	63	161.70	198.00
●	●	●	●	●	●	●	25.00	10	4.0 -25.0	67	210.10	258.50
●	●	●	●	●	●	●	31.00	12	5.0 -31.0	71	289.30	349.80

VHM Stichel

6040 30°

6050 60°

6060 90°

- Zweiseitig angeschliffene 30°/ 60° oder 90°-VHM-Stichel zum Gravieren und Fräsen von sämtlichen Werkstoffen.

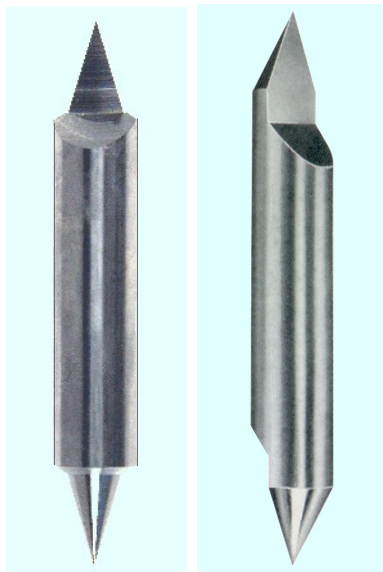

6040

6050

6060

Spitzengesamtwinkel



Alu Guss > 10% Si	Stahl < 750N	Stahl < 900N	INOX	Ti + Cu	GG (G)	Uni-versal	6040 30°	6050 60°	6060 90°				
●	●	●	○	○	●	●	Ø	Ges.-länge	Spitzenlänge				
●	●	●	○	○	●	●	Best.-Nr. 6040... 6050... 6060...						
●	●	●	○	○	●	●	..0200	2	38	4	36.30	36.30	42.90
●	●	●	○	○	●	●	..0300	3	38	5	33.00	36.30	42.90
●	●	●	○	○	●	●	..0400	4	50	6	35.20	42.90	42.60
●	●	●	○	○	●	●	..0500	5	50	7	47.30	49.50	64.90
●	●	●	○	○	●	●	..0600	6	57	8	40.70	50.60	64.90
●	●	●	○	○	●	●	..0800	8	63	10	63.80	70.40	84.70
●	●	●	○	○	●	●	..1000	10	72	12	93.50	105.60	122.10
●	●	●	○	○	●	●	..1200	12	83	14	122.10	143.00	171.60

6080

6090

6085

6100

6105

Art.-Nr. **6080** / Art.-Nr. **6090**

- **Ultra Fine:** Neuentwickelter Feinstkorn-Hartmetall 3my für Höchstleistung und höhere Standzeit.

Art.-Nr. **6085** / Art.-Nr. **6100** / Art.-Nr. **6105**

- **MICRO Grain:** Besonders preisgünstiges Feinkorn-Hartmetall für den Universal-Einsatz.

geschliffen h6

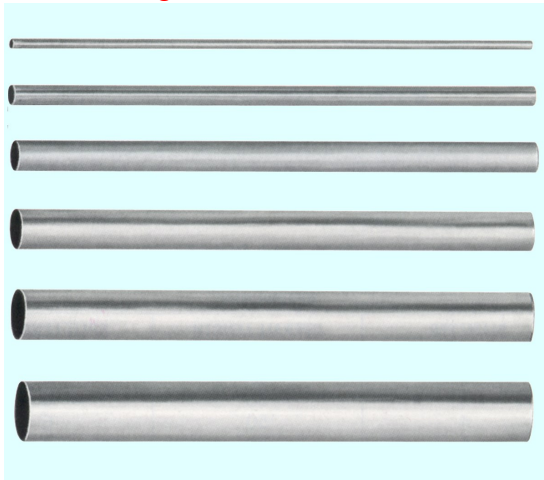

6090

6100

6105



geschliffen h6

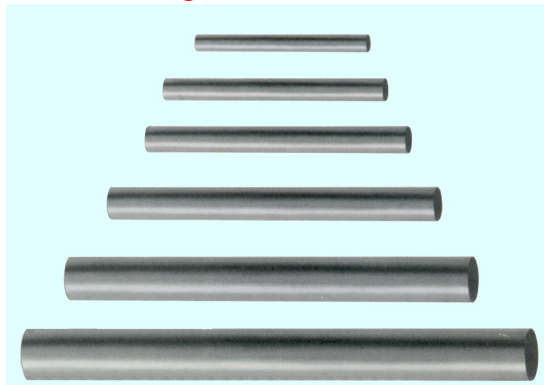

6080

6085

Best.-Nr.
6100...
6105...
6090...

Ø h ₆	6100	6105	6090	
	MICRO Grain Länge 100 mm	MICRO Grain Länge 320 mm	Ultra Fine Länge 100 mm	
..0200	2	5.-	11.00	12.10
..0250	2.5	6.-	14.30	14.30
..0300	3	7.-	16.50	15.40
..0350	3.5	7.-	19.80	19.80
..0400	4	8.-	23.10	22.00
..0450	4.5	9.-	27.50	25.30
..0500	5	10.-	34.10	26.40
..0550	5.5	12.-	38.50	30.80
..0600	6	14.-	44.00	33.00
..0650	6.5	15.-	50.60	39.60
..0700	7	17.-	49.50	44.00
..0800	8	22.-	71.50	50.60
..0900	9	26.-	83.60	68.20
..1000	10	29.-	83.60	74.80
..1200	12	40.-	140.80	106.70
..1400	14	54.-	180.40	140.80
..1600	16	68.-	225.50	182.60
..1800	18	86.-	288.20	232.10
..2000	20	106.-	360.80	292.60

Bestell.-Nr.
6085...
6080...

Ø h ₆	Länge	6085	6080	
		Micro Grain	Ultra Fine	
..0100	1	30	5.50	6.60
..0200	2	38	5.50	8.80
..0300	3	38	4.40	9.90
..0400	4	50	5.50	11.00
..0500	5	50	6.60	16.50
..0600	6	57	9.90	27.50
..0800	8	63	14.30	37.40
..1000	10	72	25.30	57.20
..1200	12	83	38.50	84.70



Art.-Nr. 6200

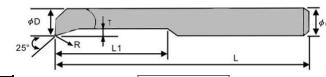

Best.-Nr. 6200...	D	L1	R	T	L	d	Preis
..010003	1	3	0.05	0.2	38	3	22.00
..010005	1	5	0.1	0.2	38	3	22.00
..020006	2	6	0.1	0.4	38	3	22.00
..020009	2	9	0.1	0.4	38	3	22.00
..030010	3	10	0.1	0.7	38	3	22.00
..030015	3	15	0.1	0.7	38	3	25.30
..040011	4	11	0.1	0.7	50	4	23.10

Best.-Nr. 6200...	D	L1	R	T	L	d	Preis
..040016	4	16	0.1	0.7	50	4	25.30
..040021	4	21	0.1	0.7	50	4	27.50
..060011	6	11	0.15	0.8	50	6	29.70
..060016	6	16	0.15	0.8	50	6	29.70
..060021	6	21	0.15	0.8	50	6	33.00
..080015	8	15	0.2	0.9	60	8	49.50
..080020	8	20	0.2	0.9	60	8	49.50

Best.-Nr. 6200...	D	L1	R	T	L	d	Preis
..080025	8	25	0.2	0.9	60	8	52.80
..100020	10	20	0.2	1	75	10	71.60
..100025	10	25	0.2	1	75	10	75.90
..100030	10	30	0.2	1	75	10	80.30



Art.-Nr. 6210

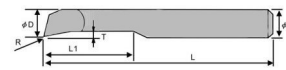

Best.-Nr. 6210...	D	L1	R	T	L	d	Preis
..040011	4	11	0.1	1	50	4	23.10
..040016	4	16	0.1	1	50	4	25.30
..040021	4	21	0.1	1	50	4	27.50

Best.-Nr. 6210...	D	L1	R	T	L	d	Preis
..060011	6	11	0.15	1.3	50	6	29.70
..060016	6	16	0.15	1.3	50	6	29.70
..060021	6	21	0.15	1.3	50	6	33.00

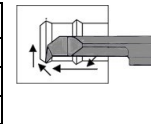

Art.-Nr. 6220

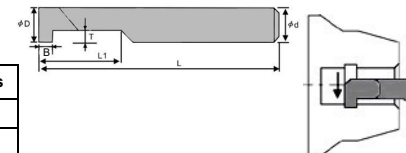

Best.-Nr. 6220...	D	B	L1	T	L	d	Preis
..030003	3	0.3	12	0.6	38	3	22.00
..030004	3	0.4	12	0.8	38	3	22.00
..040005	4	0.5	12	1.25	50	4	23.10
..040006	4	0.6	12	1.25	50	4	23.10
..040007	4	0.7	12	1.25	50	4	23.10
..040008	4	0.8	12	1.25	50	4	23.10
..060009	6	0.9	16	2	50	6	29.70

Best.-Nr. 6220...	D	B	L1	T	L	d	Preis
..060010	6	1	16	2	50	6	29.70
..060012	6	1.2	16	2	50	6	29.70
..060014	6	1.4	16	2	50	6	29.70
..060016	6	1.6	16	2	50	6	29.70
..060018	6	1.8	16	2	50	6	29.70
..080020	8	2	20	3.5	60	8	49.50
..080025	8	2.5	20	3.5	60	8	49.50

Best.-Nr. 6220...	D	B	L1	T	L	d	Preis
..100030	10	3	20	4.5	75	10	72.60
..100035	10	3.5	20	4.5	75	10	72.60
..100040	10	4	20	4.5	75	10	72.60



Art.-Nr. 6230

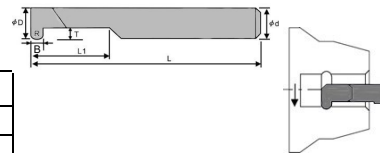

Best.-Nr. 6230...	D	R	L1	B	T	L	d	Preis
..030003	3	0.3	12	0.6	0.8	38	3	24.20
..030004	3	0.4	12	0.8	0.8	38	3	24.20
..040003	4	0.3	12	0.6	1.4	50	4	24.20
..040004	4	0.4	12	0.8	1.4	50	4	24.20
..040005	4	0.5	12	1	1.4	50	4	24.20
..040006	4	0.6	12	2	1.4	50	4	24.20
..060005	6	0.5	16	1	2	50	6	30.80

Best.-Nr. 6230...	D	R	L1	B	T	L	d	Preis
..060006	6	0.6	16	1.2	2	50	6	30.80
..060007	6	0.7	16	1.4	2	50	6	30.80
..060008	6	0.8	16	1.6	2	50	6	30.80
..060009	6	0.9	16	1.8	2	50	6	30.80
..060010	6	1	16	2	2	50	6	30.80
..080010	8	1	21	2	2.5	60	8	56.10
..080015	8	1.5	21	3	2.5	60	8	56.10

Best.-Nr. 6230...	D	R	L1	B	T	L	d	Preis
..100010	10	1	26	2	3.5	75	10	79.20
..100015	10	1.5	26	3	3.5	75	10	79.20
..100020	10	2	26	4	3.5	75	10	79.20



Art.-Nr. 6240

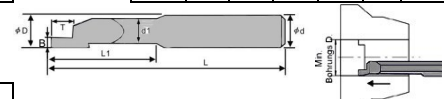

Best.-Nr. 6240...	D	B	L1	T	d1	L	d	Preis
..040007	4	0.7	12	1	3.2	50	4	24.20
..040008	4	0.8	12	1.1	3.2	50	4	24.20
..040009	4	0.9	12	1.2	3.2	50	4	24.20
..040010	4	1	12	1.3	3.2	50	4	24.20
..060007	6	0.7	16	1	5	50	6	30.80

Best.-Nr. 6240...	D	B	L1	T	d1	L	d	Preis
..060008	6	0.8	16	1.1	5	50	6	30.80
..060009	6	0.9	16	1.2	5	50	6	30.80
..060010	6	1	16	1.3	5	50	6	30.80
..060011	6	1.1	16	1.4	5	50	6	30.80
..060012	6	1.2	16	1.5	5	50	6	30.80

Best.-Nr. 6240...	D	B	L1	T	d1	L	d	Preis
..080010	8	1	20	1.3	6	60	8	55.00
..080020	8	2	20	2.3	6	60	8	55.00
..100020	10	2	25	2.3	8	75	10	79.20
..100030	10	3	25	3.5	8	75	10	79.20



Art.-Nr. 6250

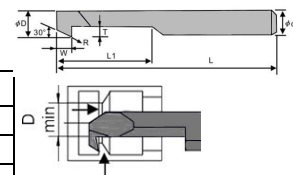

Best.-Nr. 6250...	D	L1	R	W	T	L	d	Preis
..030011	3	11	0.1	1.5	0.8	38	3	23.10
..030016	3	16	0.1	1.5	0.8	50	3	23.10
..040011	4	11	0.1	2	1.3	50	4	24.20
..040016	4	16	0.1	2	1.3	50	4	25.30
..040021	4	21	0.1	2	1.3	50	4	27.50

Best.-Nr. 6250...	D	L1	R	W	T	L	d	Preis
..060011	6	11	0.2	2	1.9	50	6	30.80
..060016	6	16	0.2	2	1.9	50	6	33.00
..060021	6	21	0.2	2	1.9	50	6	34.10



Art.-Nr. 6260 60°



Best.-Nr. 6260...	D	L1	Steigung	R	T	L	d	Preis
..024008	2.4	8	0.5	0.05	0.5	38	3	24.20
..030010	3	10	0.5-0.7	0.05	0.75	38	3	24.20
..030016	3	16	0.5-0.7	0.05	0.75	50	3	27.50
..040010	4	10	0.5-0.8	0.05	0.85	50	4	24.50
..040016	4	16	0.5-0.8	0.05	0.85	50	4	28.60
..050010	5	10	0.5-1.25	0.05	1.3	50	6	30.80

Best.-Nr. 6260...	D	L1	Steigung	R	T	L	d	Preis
..050016	5	16	0.5-1.25	0.05	1.3	50	6	33.00
..060012	6	12	0.5-1.5	0.05	1.55	50	6	30.80
..060018	6	18	0.5-1.5	0.05	1.55	50	6	34.10
..074020	7.4	20	1.0-1.5	0.08	1.9	60	8	55.00
..096020	9.6	20	1.0-2.0	0.08	2.4	75	10	79.20
..114020	11.4	20	1.0-2.0	0.08	3.2	75	12	96.80

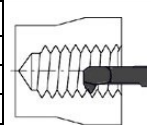

Art.-Nr. 6270 90°

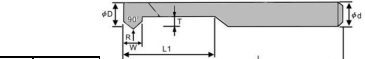

Best.-Nr. 6270...	D	L1	R	W	T	L	d	Preis
..040011	4	11	0.1	2	1.2	38	4	24.20
..040016	4	16	0.1	2	1.2	50	4	26.40
..040021	4	21	0.1	2	1.2	50	4	28.60

Best.-Nr. 6270...	D	L1	R	W	T	L	d	Preis
..060011	6	11	0.2	2.4	1.5	38	6	30.90
..060016	6	16	0.2	2.4	1.5	50	6	33.00
..060021	6	21	0.2	2.4	1.5	50	6	34.10

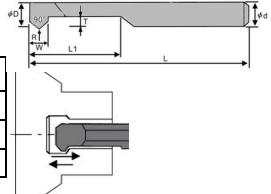

Hélice 45°
Z = 6

Hélice 30°
Z = 2



VHM - Formfräser

- Nach Zeichnung
- Präzision
- Termingerech
- Preisgünstig

Testen Sie uns!

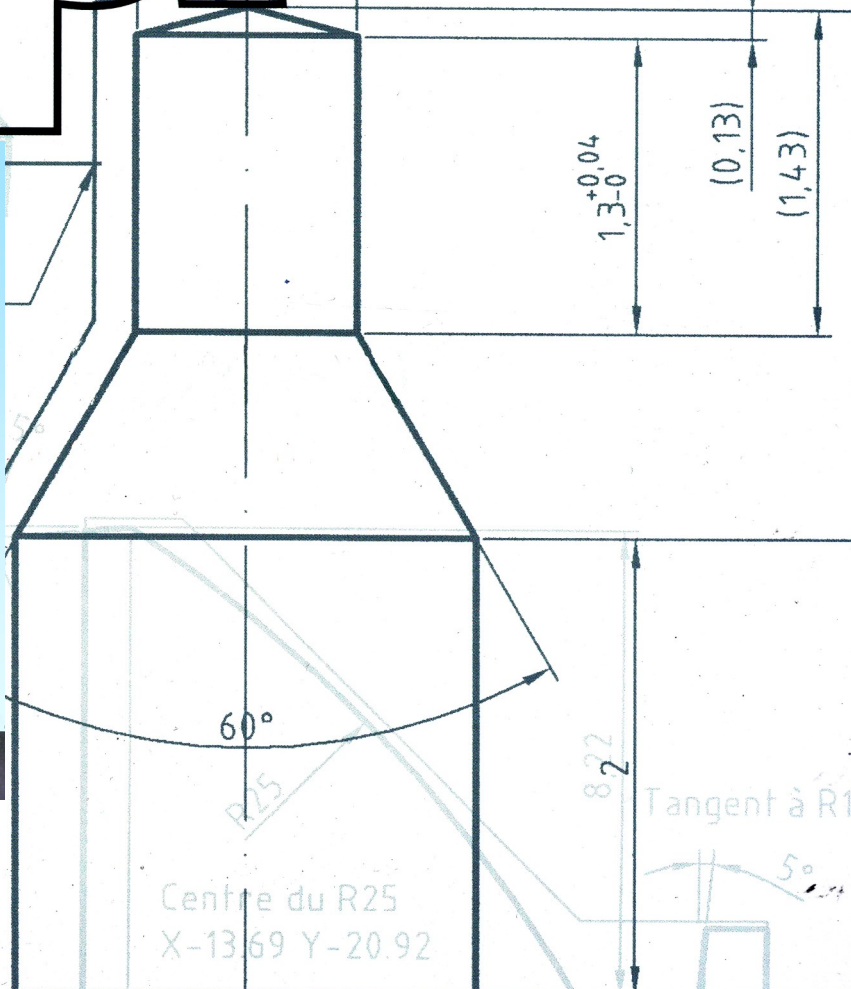
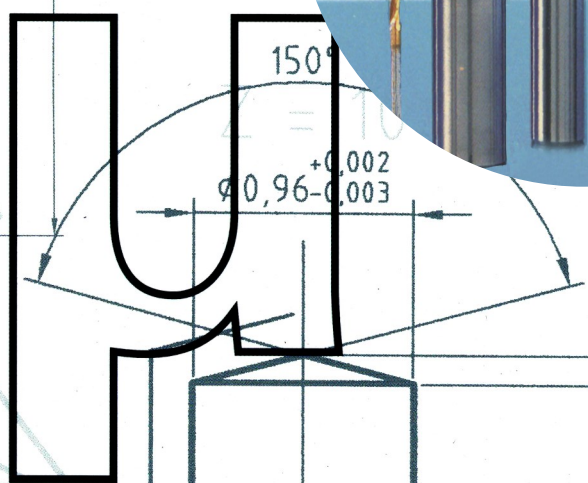
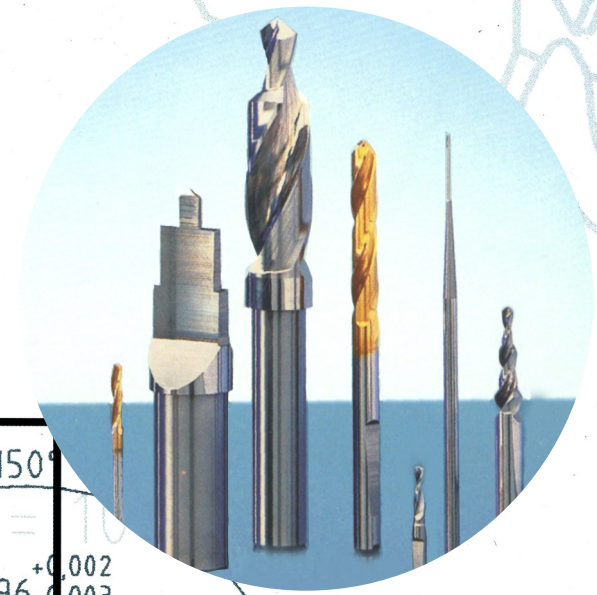

Empfohlene Schnittgeschwindigkeiten für HSSE - Fräser

		Nutfräser										Schlichtfräser										Schruppfräser								
Gruppe A		Werkstoff: Automaten-, Bau-, Einsatz-, Nitrier-, Vergütungs-, unlegierte Werkzeugstähle																						bis 700 N/mm ² , Gg < 100 HB						
Schnittmeter	Ø	2	4	6	8	10	12	16	20	30	32	4	6	8	10	12	16	20	25	30	32	6	8	10	12	16	20	25	30	32
unbeschichtet V _c 25 - 30	f _z	0.003	0.007	0.013	0.23	0.035	0.045	0.065	0.085	0.095	0.098	0.005	0.008	0.009	0.014	0.023	0.027	0.034	0.038	0.043	0.046	0.006	0.009	0.015	0.019	0.027	0.034	0.038	0.043	0.046
	n	4400	2200	1400	1000	88000	68000	53000	43000	28000	26000	2200	1400	1000	88000	68000	53000	43000	33000	28000	26000	1400	1000	88000	68000	53000	43000	33000	28000	26000
	V _f	45	46	56	69	90	94	104	101	75	70	55	42	44	58	66	62	63	84	83	75	42	44	58	66	62	63	70	69	67
Plus Future V _c 60 - 80	f _z	0.005	0.009	0.015	0.025	0.045	0.055	0.075	0.095	0.105	0.108	0.007	0.008	0.011	0.016	0.025	0.029	0.036	0.042	0.046	0.047	0.008	0.011	0.017	0.021	0.029	0.036	0.042	0.046	0.048
	n	11400	5800	3900	2900	2400	1900	1500	1200	77000	70000	5800	3900	2900	2400	1900	1500	1200	92000	77000	70000	23900	2900	2400	1900	1500	1200	92000	77000	70000
	V _f	113	114	143	175	230	238	263	249	188	180	137	106	112	147	167	157	154	216	207	200	106	112	147	167	157	154	180	173	165

		Chemisch beständige und warmfeste Stähle, legierte + rostfreie Werkzeugstähle																						bis 1100 N/mm ² , Gg > 200 HB						
Schnittmeter	Ø	2	4	6	8	10	12	16	20	30	32	4	6	8	10	12	16	20	25	30	32	6	8	10	12	16	20	25	30	32
unbeschichtet V _c 20 - 25	f _z	0.003	0.007	0.013	0.023	0.034	0.044	0.065	0.080	0.085	0.086	0.004	0.005	0.008	0.013	0.018	0.024	0.030	0.033	0.036	0.038	0.005	0.008	0.013	0.018	0.024	0.030	0.033	0.036	0.038
	n	3300	1600	1000	88000	68000	48000	43000	33000	23000	21000	1600	1000	88000	68000	48000	43000	33000	28000	23000	20000	1000	88000	68000	48000	43000	33000	28000	23000	20000
	V _f	34	34	42	52	62	62	79	75	57	50	34	26	32	39	42	45	43	61	56	50	26	32	39	42	45	43	51	46	42
Plus Future V _c 50 - 60	f _z	0.005	0.009	0.015	0.025	0.036	0.046	0.075	0.090	0.095	0.095	0.006	0.007	0.010	0.015	0.020	0.026	0.032	0.035	0.038	0.040	0.007	0.010	0.015	0.020	0.026	0.032	0.035	0.038	0.040
	n	8100	4100	2800	2100	1700	1300	1100	82000	57000	54000	4100	2800	2100	1700	1300	1100	82000	67000	57000	54000	2800	2100	1700	1300	1100	82000	67000	57000	54000
	V _f	98	80	102	115	140	146	175	170	124	120	80	65	72	90	100	100	100	133	122	120	65	72	90	100	100	100	110	102	120

		Chemisch beständige Stähle, legierte Stähle, Kaltarbeits-, Schnellarbeits-, Ventil- + rostfreie Stähle																						bis 1400 N/mm ²						
Schnittmeter	Ø	2	4	6	8	10	12	16	20	30	32	4	6	8	10	12	16	20	25	30	32	6	8	10	12	16	20	25	30	32
unbeschichtet V _c 10 - 16	f _z	0.002	0.006	0.011	0.015	0.025	0.035	0.55	0.75	0.084	0.086	0.005	0.006	0.009	0.014	0.019	0.024	0.032	0.035	0.039	0.042	0.006	0.009	0.014	0.019	0.024	0.032	0.035	0.039	0.039
	n	2300	1100	78000	58000	48000	38000	28000	23000	13000	10000	1100	78000	58000	48000	38000	28000	23000	18000	13000	10000	78000	58000	48000	38000	28000	23000	18000	13000	10000
	V _f	18	21	24	30	40	40	49	50	32	28	29	22	24	30	32	31	33	43	35	30	22	24	30	32	31	33	36	29	25
Plus Future V _c 12 - 35	f _z	0.004	0.008	0.013	0.025	0.035	0.045	0.065	0.085	0.090	0.095	0.007	0.008	0.011	0.016	0.021	0.026	0.034	0.037	0.041	0.042	0.008	0.011	0.016	0.021	0.026	0.034	0.037	0.041	0.042
	n	4200	2200	1500	1100	82000	72000	52000	42000	32000	25000	2200	1500	1100	82000	72000	52000	42000	37000	32000	28000	1500	1100	82000	72000	52000	42000	37000	32000	27000
	V _f	31	37	42	50	64	70	82	80	64	50	50	39	40	48	56	52	53	76	70	70	39	40	48	56	52	53	63	59	68

		Schwer zerspanbare Materialien, hochwarmfeste Stähle, Ti- und Ni-Legierungen																												
Schnittmeter	Ø	2	4	6	8	10	12	16	20	30	32	4	6	8	10	12	16	20	25	30	32	6	8	10	12	16	20	25	30	32
unbeschichtet V _c 3 - 12	f _z	0.001	0.005	0.009	0.015	0.027	0.034	0.054	0.065	0.069	0.080	0.005	0.006	0.010	0.014	0.021	0.027	0.034	0.036	0.042	0.044	0.006	0.010	0.015	0.019	0.027	0.034	0.036	0.042	0.044
	n	1300	68000	48000	33000	28000	23000	16000	12000	8000	6000	68000	48000	33000	28000	23000	16000	12000	9000	8000	6000	48000	33000	28000	23000	16000	12000	9000	8000	6000
	V _f	7	10	13	17	21	22	25	23	18	15	17	14	15	19	22	20	20	24	26	26	14	15	19	22	20	20	20	22	22
Plus Future V _c 5 - 30	f _z	0.003	0.007	0.011	0.021	0.029	0.036	0.056	0.067	0.072	0.075	0.007	0.008	0.012	0.016	0.023	0.029	0.036	0.038	0.044	0.045	0.008	0.012	0.017	0.021	0.029	0.036	0.038	0.044	0.045
	n	2600	1300	82000	62000	52000	42000	32000	27000	17000	15000	1300	82000	62000	52000	42000	32000	27000	22000	17000	15000	82000	62000	52000	42000	32000	27000	22000	17000	15000
	V _f	13	18	20	29	35	35	42	41	27	22	29	22	26	32	35	34	35	44	39	40	22	26	32	35	34	35	37	32	40

		Kupfer/Messing, Kupferlegierungen																												
Schnittmeter	Ø	2	4	6	8	10	12	16	20	30	32	4	6	8	10	12	16	20	25	30	32	6	8	10	12	16	20	25	30	32
unbeschichtet V _c 40 - 70	f _z	0.004	0.008	0.019	0.031	0.045	0.060	0.095	0.125	0.175	0.190	0.009	0.014	0.022	0.034	0.038	0.045	0.055	0.065	0.085	0.090	0.013	0.023	0.034	0.038	0.045	0.055	0.065	0.085	0.090
	n	8700	4300	2800	2100	1700	1400	1000	88000	58000	42000	4300	2800	2100	1700	1400	1000	88000	68000	58000	48000	2800	2100	1700	1400	1000	88000	68000	58000	48000
	V _f	110	100	145	175	225	243	275	290	270	250	130	120	150	190	180	165	160	150	160	160	120	150	190	180	165	160	150	160	160
Plus Future V _c 80 - 150	f _z	0.006	0.010	0.021	0.033	0.055	0.070	0.105	0.135	0.185	0.190	0.011	0.016	0.024	0.036	0.045	0.055	0.065	0.075	0.095	0.100	0.015	0.025	0.036	0.045	0.055	0.065	0.075	0.095	0.100
	n	15100	7700	5100	3900	3100	2600	2000	1600	1100	1000	7700	5100	3900	3100	2600	2000	1600	1300	1100	1100	5100	3900	3100	2600	2000	1600	1300	1100	1100
	V _f	188	170	250	300	375	408	475	490	450	390	300	280	350	430	400	380	300	500	540	460	280	350	430	400	380	360	420	450	500

		Aluminium + Magnesiumlegierungen																												
Schnittmeter	Ø	2	4	6	8	10	12	16	20	30	32	4	6	8	10	12	16	20	25	30	32	6	8	10	12	16	20	25	30	32
unbeschichtet V _c 200 - 300	f _z	0.003	0.007	0.013	0.024	0.035	0.045	0.075	0.105	0.165	0.180	0.006	0.007	0.013	0.019	0.028	0.036	0.045	0.055	0.070	0.072	0.007	0.014	0.019	0.028	0.037	0.045	0.055	0.070	0.072
	n	39900	19900	13200	9900	7900	6500	4900	3900	2600	2100	19900	13200	9900	7900	6500	4900	3900	3100	2600	2100	13200	9900	7900	5900	4900	3900	3100	2600	2100
	V _f	385	400	500	625	800	825	1.0	1.1	1.15	1.2	420	320	420	500	580	550	600	570	600	620	320	420	500	580	550	600	580	610	630
Plus Future V _c 300 - 600	f _z	0.005	0.009	0.015	0.026	0.045	0.055	0.085	0.115	0.175	0.190	0.008	0.009	0.015	0.021	0.030	0.038	0.055	0.065	0.080	0.085	0.009	0.016	0.022	0.030	0.039	0.055	0.065	0.080	0.085
	n	63800	32100	21300	16100	12800	10700	8100	6500	4300	4100	32100	21300	16100	12800	10700	8100	6500	5200	4300	4100	21300	16100	12800	10700					

Empfohlene Schnittgeschwindigkeiten für **VHM - Fräser**

Art.-Nr.		4020 / 4020 B / 4030 B / 4040 / 4040 B / 4050 4050 B / 4055 / 4055 B / 4060 / 4060 B / 4070								4060 / 4060 B / 4070 / 4070 B / 4080 / 4080 B 4090 / 4090 B / 4095 / 4095 B / 5038 / 5038 B								5011 B / 5050 B / 5055 B / 5060 B 5061 B / 5062 B / 5065 B							
Gruppe A		Nutfräser 2 Z + 3 Z								Schlichtfräser 4 Z								Schruppfräser 4 Z							
		Werkstoff: Automaten-, Bau-, Einsatz-, Nitrier-, Vergütungs-, unlegierte Werkzeugstähle bis 700 N/mm ² , Gg < 100 HB																							
Schnittmeter	Ø	2	4	6	8	10	12	16	20	2	4	6	8	10	12	16	20	4	6	8	10	12	16	20	
unbeschichtet V _c 90 - 120	f _z	0.004	0.009	0.015	0.020	0.025	0.030	0.040	0.060	0.005	0.013	0.020	0.025	0.030	0.040	0.060	0.080	0.020	0.030	0.030	0.040	0.040	0.040	0.070	
	n	15900	7900	5300	3900	3100	2600	1900	1500	15900	7900	5300	3900	3100	2600	1900	1500	8700	5800	4300	3500	2900	2200	1700	
	V _f	120	140	160	160	160	160	160	200	320	420	420	420	420	420	480	500	696	696	516	560	696	352	476	
Extrem Speed V _c 130 - 150	f _z	0.004	0.009	0.015	0.020	0.025	0.030	0.040	0.060	0.005	0.013	0.020	0.025	0.030	0.040	0.060	0.080	0.040	0.050	0.050	0.070	0.070	0.070	0.080	
	n	23800	11900	7900	5900	4700	3900	2900	2300	23800	11900	7900	5900	4700	3900	2900	2300	11100	7400	5500	4400	3700	2800	2200	
	V _f	200	220	240	240	240	240	240	280	480	620	620	620	620	640	720	760	1776	1480	1100	1232	1036	784	704	

Gruppe B		Chemisch beständige und wärmfeste Stähle, legierte + rostfreie Werkzeugstähle bis 1100 N/mm ² , Gg > 200 HB																						
Schnittmeter	Ø	2	4	6	8	10	12	16	20	2	4	6	8	10	12	16	20	4	6	8	10	12	16	20
unbeschichtet V _c 85 m/min	f _z	0.002	0.006	0.012	0.014	0.018	0.023	0.033	0.048	0.006	0.009	0.011	0.014	0.018	0.023	0.033	0.038	0.010	0.010	0.010	0.020	0.020	0.030	0.040
	n	16000	8000	5300	4000	3200	2600	2000	1600	16000	8000	5300	4000	3200	2600	2000	1600	6700	4500	3400	2700	2200	1700	1300
	V _f	145	170	200	180	190	195	210	240	430	300	250	220	250	260	280	240	268	180	136	216	176	204	208
Extrem Speed V _c 105 m/min	f _z	0.004	0.008	0.014	0.016	0.022	0.027	0.037	0.052	0.008	0.011	0.013	0.016	0.022	0.027	0.037	0.042	0.020	0.030	0.040	0.050	0.050	0.060	0.070
	n	21000	10400	6900	5200	4000	3400	2600	2100	21000	14000	6900	5200	4000	3400	2600	2100	8300	5500	4200	3300	2800	2100	1700
	V _f	180	220	260	230	250	250	260	320	570	400	320	300	330	340	360	340	664	660	672	660	560	504	476

Gruppe C		Chemisch beständige Stähle, legierte Stähle, Kaltarbeits-, Schnellarbeits-, Ventil- + rostfreie Stähle bis 1400 N/mm ²																						
Schnittmeter	Ø	2	4	6	8	10	12	16	20	2	4	6	8	10	12	16	20	4	6	8	10	12	16	20
unbeschichtet V _c 65 m/min	f _z	0.002	0.006	0.012	0.014	0.018	0.023	0.028	0.048	0.006	0.009	0.011	0.014	0.018	0.023	0.033	0.038	0.010	0.010	0.010	0.020	0.020	0.030	0.040
	n	11000	5700	3800	2800	2200	1800	1400	1100	11000	5600	3800	2800	2200	1800	1400	1100	5200	3400	2600	2100	1700	1300	1000
	V _f	100	125	140	120	130	140	150	160	300	220	180	170	160	180	200	180	208	136	104	168	136	156	160
Extrem Speed V _c 75 m/min	f _z	0.004	0.008	0.014	0.016	0.022	0.026	0.032	0.051	0.008	0.011	0.013	0.016	0.022	0.027	0.037	0.042	0.020	0.030	0.040	0.050	0.050	0.060	0.070
	n	18000	8800	6000	4500	3600	3000	2100	1800	18000	8500	5700	4500	3500	3000	2200	1800	5900	3900	2900	2400	2000	1500	1200
	V _f	160	180	230	200	210	230	240	270	500	340	280	260	280	300	300	280	472	468	464	480	400	360	336

Gruppe D		Schwer zerspanbare Materialien, hochwärmfeste Stähle, Ti- und Ni-Legierungen																						
Schnittmeter	Ø	2	4	6	8	10	12	16	20	2	4	6	8	10	12	16	20	4	6	8	10	12	16	20
unbeschichtet V _c 50 m/min	f _z	0.002	0.006	0.012	0.14	0.018	0.023	0.033	0.048	0.006	0.009	0.011	0.014	0.018	0.023	0.033	0.038	0.020	0.020	0.020	0.030	0.030	0.040	0.050
	n	8800	4300	3000	2200	1800	1400	1100	900	8800	4300	3000	2200	1800	1400	1100	900	3900	2600	2000	1600	1300	900	800
	V _f	80	95	120	105	115	115	115	130	240	180	150	130	150	150	150	150	312	208	160	192	156	36	40
Extrem Speed V _c 60 m/min	f _z	0.004	0.008	0.014	0.016	0.022	0.027	0.037	0.052	0.008	0.011	0.013	0.016	0.022	0.027	0.037	0.042	0.050	0.040	0.050	0.060	0.060	0.070	0.080
	n	15000	7000	4800	3600	2800	2400	1800	1500	15000	7000	4800	3600	2800	2400	1800	1500	4700	3200	2400	1900	1600	1200	900
	V _f	130	155	180	165	170	180	195	215	410	280	210	210	220	250	260	220	564	512	480	456	384	336	288

Gruppe E		Kupfer/Messing, Kupferlegierungen																						
Schnittmeter	Ø	2	4	6	8	10	12	16	20	2	4	6	8	10	12	16	20	4	6	8	10	12	16	20
unbeschichtet V _c 140 - 160	f _z	0.004	0.009	0.015	0.020	0.025	0.030	0.040	0.060	0.005	0.013	0.020	0.025	0.030	0.040	0.060	0.080	0.020	0.030	0.030	0.050	0.050	0.070	0.090
	n	23800	11900	7900	5900	4700	3900	2900	2300	23800	11900	7900	5900	4700	3900	2900	2300	11900	7900	5900	4700	3900	2900	2400
	V _f	220	220	240	240	240	240	240	280	480	620	620	620	620	640	720	760	952	948	708	940	780	812	864
Extrem Speed V _c 200 - 220	f _z	0.004	0.009	0.015	0.020	0.025	0.030	0.040	0.060	0.005	0.013	0.020	0.025	0.030	0.040	0.060	0.080	0.040	0.050	0.060	0.070	0.080	0.100	0.120
	n	35000	17500	11600	8700	7000	5800	4300	3500	35000	17500	11600	8700	7000	5800	4300	3500	16700	11100	8300	6700	5600	4100	3300
	V _f	280	320	360	360	360	360	360	420	700	920	940	920	920	940	1060	1120	2672	2220	1992	1876	1792	1640	1584

Gruppe F		Aluminium + Magnesiumlegierungen																						
Schnittmeter	Ø	2	4	6	8	10	12	16	20	2	4	6	8	10	12	16	20	4	6	8	10	12	16	20
unbeschichtet V _c 250 - 300	f _z	0.004	0.009	0.015	0.020	0.025	0.030	0.040	0.060	0.005	0.013	0.020	0.025	0.030	0.040	0.060	0.080	0.040	0.050	0.050	0.080	0.080	0.120	0.160
	n	40200	20300	13700	10400	8400	7100	5400	4400	40200	20300	13700	10400	8400	7100	5400	4500	22000	14800	11200	9100	7600	5800	4800
	V _f	320	360	400	400	400	400	400	480	800	1040	1040	1040	1040	1040	1200	1280	3440	2860	2140	2752	2272	2544	2752
Extrem Speed V _c 400 - 800	f _z	0.004	0.009	0.015	0.020	0.025	0.030	0.040	0.060	0.005	0.013	0.020	0.025	0.030	0.040	0.060	0.080	0.060	0.070	0.080	0.120	0.120	0.160	0.200
	n	59300	29900	20100	15200	12200	10300	7800	6300	59300	29900	20100	15200	12200	10300	7800	6300	48300	32300	24400	19600	16400	12400	10000
	V _f	480	540	580	580	580	580	580	700	1180	1580	1580	1580	1580	1580	1760	1880	11472	8904	7648	9168	7632	7616	1900

Empfohlene Schnittgeschwindigkeiten für VHM - HSC - Fräser

Art.-Nr.

4090 B / 4095 B / 5035 B / 5040 B / 5041 B
5070 B / 5080 B / 5090 B / 6000 B / 6010 B

5045 B / 5050 B / 5055 B
5060 B / 5062 B / 5065 B

		Schlichtfräser						Schruppfräser					
Gruppe A		Werkstoff: Automaten-, Bau-, Einsatz-, Nitrier-, Vergütungs-, unlegierte Werkzeugstähle										bis 700 N/mm ² , Gg < 100 HB	
	Ø	6	8	10	12	16	20	6	8	10	12	16	20
Schnittmeter V _c		210 m/min						170 m/min					
<i>Extrem Speed</i>	f _z	0.03	0.05	0.07	0.09	0.09	0.11	0.03	0.05	0.07	0.09	0.09	0.11

Gruppe B		Chemisch beständige und warmfeste Stähle, legierte + rostfreie Werkzeugstähle										bis 1100 N/mm ² , Gg > 200 HB	
	Ø	6	8	10	12	16	20	6	8	10	12	16	20
Schnittmeter V _c		150 m/min						130 m/min					
<i>Extrem Speed</i>	f _z	0.03	0.05	0.07	0.09	0.09	0.11	0.03	0.05	0.07	0.09	0.09	0.11

Gruppe C		Chemisch beständige Stähle, legierte Stähle, Kaltarbeits-, Schnellarbeits-, Ventil- + rostfreie Stähle										bis 1400 N/mm ²	
	Ø	6	8	10	12	16	20	6	8	10	12	16	20
Schnittmeter V _c		98 m/min						120 m/min					
<i>Extrem Speed</i>	f _z	0.15	0.015	0.04	0.05	0.05	0.07	0.15	0.015	0.04	0.05	0.05	0.07

Gruppe D		Schwer zerspanbare Materialien, hochwarmfeste Stähle, Ti- und Ni-Legierungen											
	Ø	6	8	10	12	16	20	6	8	10	12	16	20
Schnittmeter V _c		92 m/min						76 m/min					
<i>Extrem Speed</i>	f _z	0.15	0.015	0.04	0.05	0.05	0.07	0.15	0.015	0.04	0.05	0.05	0.07

Gruppe E		Kupfer/Messing, Kupferlegierungen											
	Ø	6	8	10	12	16	20	6	8	10	12	16	20
Schnittmeter V _c		78 m/min						65 m/min					
<i>Extrem Speed</i>	f _z	0.15	0.015	0.04	0.05	0.05	0.07	0.15	0.015	0.04	0.05	0.05	0.07

Gruppe F		Alu-Guss, ausgehärtetes Alu											
	Ø	6	8	10	12	16	20	6	8	10	12	16	20
Schnittmeter V _c		365 m/min						300 m/min					
<i>Extrem Speed</i>	f _z	0.03	0.05	0.07	0.11	0.11	0.15	0.03	0.05	0.07	0.11	0.11	0.15

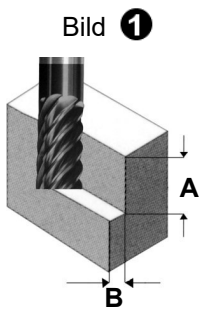

Empfohlene Schnittgeschwindigkeiten für VHM - Cutter - Fräser hartfräsen

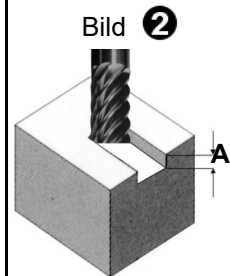

Art.-Nr.

5000 B / 5010 B / 5012 B / 5013 B
5015 B / 5017 B / 5020 B / 5030 B

Stahl	40 - 48 HRC Umfangfräsen ① A = 1,4 x d Vc = 150 m/min B = max. 0,06 x d								40 - 48 HRC Nutfräsen ② A = max 0,24 x d Vc = 70 m/min							
	Ø	2	4	6	8	10	12	16	20	2	4	6	8	10	12	16
Vorschub pro Zahn fz	0.010	0.015	0.030	0.040	0.050	0.060	0.060	0.075	0.015	0.020	0.035	0.045	0.055	0.065	0.090	0.100
Umdrehungen pro min. n	18500	11935	7960	5970	4775	3980	2985	2385	7425	5570	3715	2785	2230	1855	1395	1250
Vorschub pro min. Vf	635	715	1435	1435	1435	1435	1075	1430	225	225	520	500	490	480	500	480

Stahl	50 - 58 HRC Umfangfräsen ① A = 1,4 x d								50 - 58 HRC Nutfräsen ② A = max 0,19 x d							
	Ø	2	4	6	8	10	12	16	20	2	4	6	8	10	12	16
Vorschub pro Zahn fz	0.010	0.015	0.030	0.040	0.050	0.060	0.060	0.075	0.015	0.020	0.035	0.045	0.055	0.065	0.090	0.100
Umdrehungen pro min. n	8490	6365	4245	3185	2545	2120	1590	1275	5305	3980	2655	1990	1590	1325	995	925
Vorschub pro min. Vf	340	380	765	765	765	765	570	765	160	160	370	360	350	345	360	320

Stahl	58 - 62 HRC Umfangfräsen ① A = 1,4 x d								58 - 62 HRC Nutfräsen ② A = max 0,14 x d							
	Ø	2	4	6	8	10	12	16	20	2	4	6	8	10	12	16
Vorschub pro Zahn fz	0.010	0.010	0.015	0.025	0.030	0.035	0.045	0.055	0.008	0.015	0.030	0.040	0.050	0.060	0.075	0.095
Umdrehungen pro min. n	3185	2385	1590	1195	955	795	595	475	3185	2385	1590	1195	955	795	595	580
Vorschub pro min. Vf	127	95	143	179	172	167	161	209	50	70	190	190	190	190	180	170

Stahl	62 - 70 HRC Umfangfräsen ① A = 1,4 x d								62 - 70 HRC Nutfräsen ② A = max 0,09 x d							
	Ø	2	4	6	8	10	12	16	20	2	4	6	8	10	12	16
Vorschub pro Zahn fz	0.008	0.010	0.015	0.020	0.025	0.030	0.040	0.055	0.008	0.010	0.015	0.020	0.025	0.030	0.040	0.050
Umdrehungen pro min. n	2120	1590	1060	795	635	530	400	320	2120	1590	1060	795	635	530	400	380
Vorschub pro min. Vf	68	64	95	95	95	95	96	141	34	32	64	64	64	64	64	64

Hochgeschwindigkeitsbearbeitung / High Speed Cutting ①		A = 0,9 x d / B = - Ø 12 = 0,009 x d / ab Ø 12 = 0,019 x d						
	Stahl	Schnittgeschwindigkeit	Ø 6	8	10	12	16	20
Drehzahl min ⁻¹	bis 700 N/mm ²	Vc = 350 - 500 m/min	20.500	16.500	13.500	11.500	8.500	6.500
Vorschubgeschwindigkeit mm/min			3.600	4.100	4.100	3.900	3.400	2.700
Drehzahl min ⁻¹	bis 28 HRC	Vc = 300 - 440 m/min	19.500	15.500	12.000	10.100	7.500	5.800
Vorschubgeschwindigkeit mm/min			3.200	3.600	3.600	3.400	3.000	2.300
Drehzahl min ⁻¹	30 - 35 HRC	Vc = 250 - 380 m/min	15.500	10.500	9.100	7.500	5.500	4.200
Vorschubgeschwindigkeit mm/min			2.700	2.700	2.700	2.500	2.200	1.800
Drehzahl min ⁻¹	35 - 48 HRC	Vc = 150 - 280 m/min	12.500	9.500	7.500	6.000	4.500	3.500
Vorschubgeschwindigkeit mm/min			1.900	1.900	1.900	1.700	1.500	1.300
Drehzahl min ⁻¹	48 - 55 HRC	Vc = 120 - 200 m/min	8.100	6.000	4.600	3.800	2.700	2.100
Vorschubgeschwindigkeit mm/min			1.220	1.220	1.220	1.020	920	720
Drehzahl min ⁻¹	55 - 60 HRC	Vc = 80 - 160 m/min	5.900	4.300	3.300	2.700	1.900	1.500
Vorschubgeschwindigkeit mm/min			880	880	880	770	720	560

Alle in diesem Katalog angegebenen Schnittwerte sind zwar praxiserprobt aber unverbindliche Richtwerte.
Gute Kühlung und Werkstückbefestigung sowie ausreichende Maschinenleistung sind Voraussetzung.

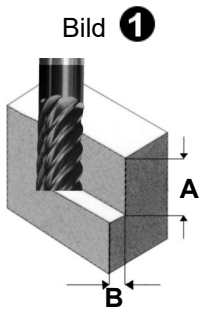

Empfohlene Schnittgeschwindigkeiten für VHM-MICRO Fräser

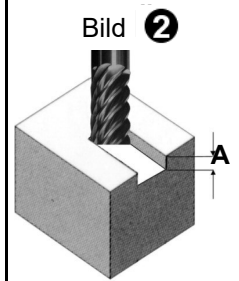

Art.-Nr.

4010 / 4015 / 4017 / 4018
4010 B / 4015 B / 4017 B / 4018 B

Stahl 20 - 30 HRC	Umfangfräsen 1 A = 1,4 x d B = max. 0,06 x d Vc = 130 m/min										20 - 30 HRC Nutfräsen 2 A = max 0,2 x d Vc = 110 m/min									
	Ø	0,1-0,2	0,3-0,5	0,6-0,9	1,0-1,2	1,3-1,5	1,6-1,9	2,0-2,3	2,4-2,7	2,8-3,0	0,1-0,2	0,3-0,5	0,6-0,9	1,0-1,2	1,3-1,5	1,6-1,9	2,0-2,3	2,4-2,7	2,8-3,0	
Vorschub pro Zahn f_z	0.003	0.005	0.015	0.025	0.030	0.035	0.040	0.050	0.060	0.003	0.005	0.010	0.015	0.020	0.022	0.025	0.030	0.040		
Umdrehungen pro min. n	80000	60000	54570	31830	25465	22450	19100	15280	12735	80000	60000	45475	26525	21220	18850	15915	12735	10610		
Vorschub pro min. V_f	500	600	1635	1590	1530	1530	1530	1530	1530	500	600	910	795	850	820	795	765	850		

Stahl 32 - 48 HRC	Umfangfräsen 1 A = 1,4 x d B = max. 0,04 x d Vc = 90 m/min										50 - 58 HRC Nutfräsen 2 A = max 1,5 x d Vc = 80 m/min									
	Ø	0,1-0,2	0,3-0,5	0,6-0,9	1,0-1,2	1,3-1,5	1,6-1,9	2,0-2,3	2,4-2,7	2,8-3,0	0,1-0,2	0,3-0,5	0,6-0,9	1,0-1,2	1,3-1,5	1,6-1,9	2,0-2,3	2,4-2,7	2,8-3,0	
Vorschub pro Zahn f_z	0.003	0.005	0.015	0.025	0.030	0.035	0.040	0.050	0.060	0.003	0.005	0.010	0.015	0.020	0.022	0.025	0.030	0.040		
Umdrehungen pro min. n	70000	60000	36380	21220	16975	14850	12735	10185	8490	70000	60000	31830	18570	14855	12850	11140	8915	7425		
Vorschub pro min. V_f	500	600	1090	1060	1020	1020	1020	1020	1020	500	600	635	555	595	575	555	535	595		

Kupfer	Umfangfräsen 1 A = 1,4 x d										Nutfräsen 2 A = max 1,1 x d									
	Ø	0,1-0,2	0,3-0,5	0,6-0,9	1,0-1,2	1,3-1,5	1,6-1,9	2,0-2,3	2,4-2,7	2,8-3,0	0,1-0,2	0,3-0,5	0,6-0,9	1,0-1,2	1,3-1,5	1,6-1,9	2,0-2,3	2,4-2,7	2,8-3,0	
Vorschub pro Zahn f_z	0.003	0.005	0.015	0.025	0.030	0.035	0.040	0.050	0.060	0.003	0.005	0.010	0.015	0.020	0.022	0.025	0.030	0.040		
Umdrehungen pro min. n	70000	60000	60000	60000	48810	41650	36605	29285	24405	70000	60000	60000	60000	48810	41840	36605	29285	24405		
Vorschub pro min. V_f	500	600	1800	3000	2930	2930	2930	2930	2930	500	600	1200	1800	1950	1890	1830	1755	1950		

Aluminium	Umfangfräsen 1 A = 1,4 x d										Nutfräsen 2 A = max 0,11 x d									
	Ø	0,1-0,2	0,3-0,5	0,6-0,9	1,0-1,2	1,3-1,5	1,6-1,9	2,0-2,3	2,4-2,7	2,8-3,0	0,1-0,2	0,3-0,5	0,6-0,9	1,0-1,2	1,3-1,5	1,6-1,9	2,0-2,3	2,4-2,7	2,8-3,0	
Vorschub pro Zahn f_z	0.003	0.005	0.015	0.025	0.030	0.035	0.040	0.050	0.060	0.003	0.005	0.010	0.015	0.020	0.022	0.025	0.030	0.040		
Umdrehungen pro min. n	80000	60000	60000	60000	60000	60000	60000	60000	50930	80000	60000	60000	60000	60000	60000	60000	60000	50930		
Vorschub pro min. V_f	500	600	1800	3000	3600	4100	4800	6000	6110	500	600	1200	1800	2400	2700	3000	3600	4075		

Berechnung von Schnittwerten

V_c = Schnittgeschwindigkeit

n = Umdrehung pro min.

V_f = Vorschub pro min.

Z = Zähnezahl

\varnothing_c = Fräserdurchmesser

S = Vorschub pro Umdrehung

f_z = Vorschub pro Zahn

Formel

$$S = \frac{V_f}{n}$$

$$V_c = \frac{3,14 \times \varnothing_c \times n}{1000}$$

$$f_z = \frac{V_f}{n \times z}$$

$$n = \frac{V_c \times 1000}{3,14 \times \varnothing_c}$$

$$V_f = n \times z \times f_z$$

Alle in diesem Katalog angegebenen Schnittwerte sind zwar praxiserprobt aber unverbindliche Richtwerte.

NOTIZEN

A sheet of white paper with horizontal ruling lines. The lines are evenly spaced and extend across the width of the page. The paper is oriented vertically. The top of the page has the word "NOTIZEN" centered in a bold, black, sans-serif font. The rest of the page is blank, with only the ruling lines visible.

VHM Indexfräser - Changesystem

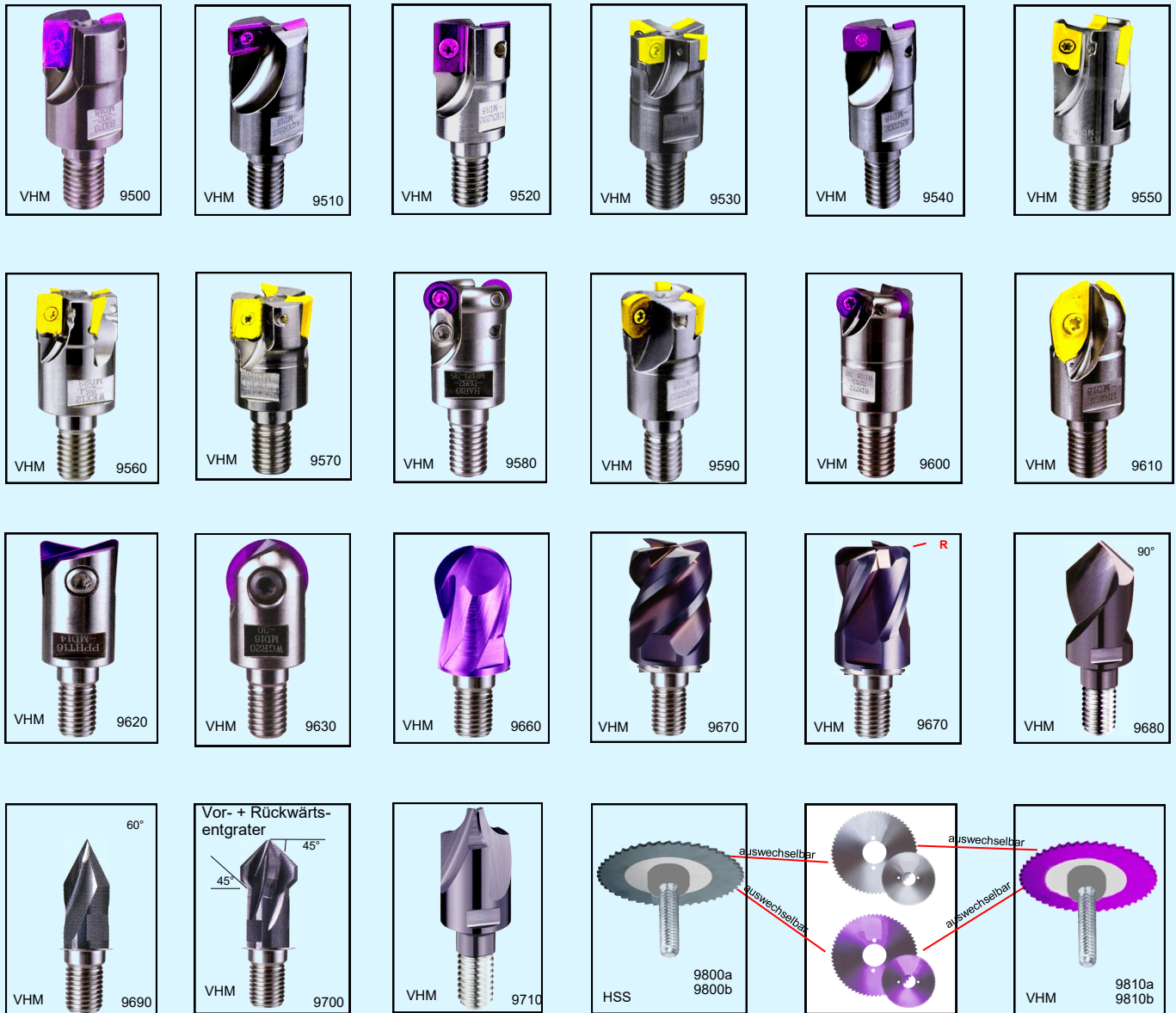

Nutfräser in jeder Breite lieferbar

1 VHM Aufnahmehalter = 19 - 300 Fräsermöglichkeiten

