

Wendeplatten Fräser



VHM - Wendeplatten - Fräser



Ecknutenfräser	4/10
Bohr- Senkfräser	4/10
Kopierfräser	4/10
Hochleistungs-Eckfräser	4/11
Kopier- + Planfräser	4/11
Radius- Kopierfräser	4/11
Kopierfräser	4/12
Fasenfräser 30° 45° 60°	4/12

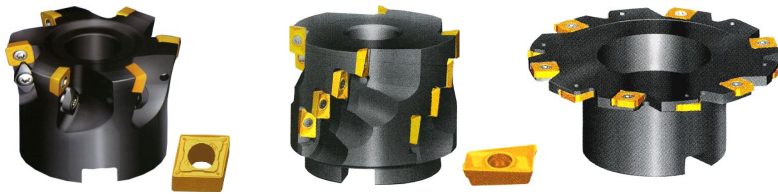

Planfräser	4/13
Hoch - Vorschub - Planfräser	4/13
Walzenstirnfräser Eckfräser	4/13
Planfräser	4/14
Messerköpfe-Planfräser	4/14
Scheibenfräser	4/14

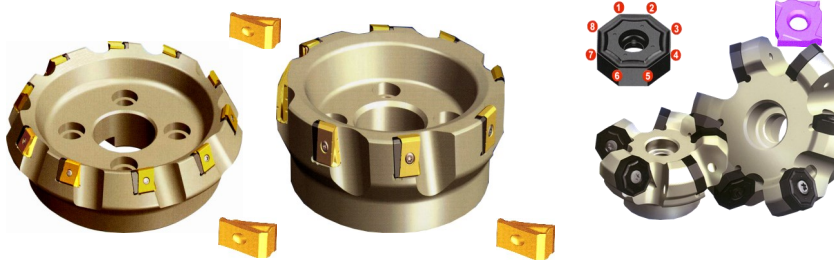

Tangential - Hochleistungs - Fräser 60° 75° 89°	4/15
Planfräser mit 16 Schneidkanten 45°	4/16
Schafffräser mit 16 Schneidkanten 45°	4/16

VHM-WP - Eck- Nutenfräser

9300



90°

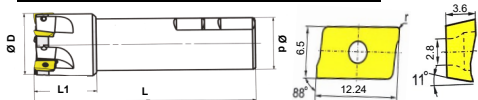

Materialeignung ● Sehr Gut ○ Gut	Alu	Alu Guss > 10% Si	Stahl > 750N	Stahl > 900N	Stahl > 1400N	Stahl > 55 HRC	Stahl > 60 HRC	Hochvergütete Stähle	INOX	TITAN / Cu	GG (G)	Universal
9301 TIN		●	●	●	●	○			○	○	○	●
9301 ALU	●	●							○	●	○	●
9302 TIALN		●	●	●	●	●		●	●	●	●	●

VHM-Wendeplatten



TIN-Beschichtet



f. ALU + Kunststoff



TIALN-Beschichtet
für INOX



Art.-Nr.	Abmessungen mm							Preis CHF ohne Platte	Art.-Nr.	Preis	Art.-Nr.	Preis	Art.-Nr.	Preis	Schraube	Schlüssel
	φD	φd	L	L1	ap	Z										
9300 12	12	16	85	25	11	1	90.30	APKT....		APKT....		APKT....				
9300 16	16	16	90	25	11	2	102.90	9301 R 0.4	11.60	9301 AL R 0.4	10.2	9302 R 0.4	12.70	9305 M2.5x6.5 CHF 3.40	9306 T08 CHF 4.40	
9300 20	20	20	100	30	11	2	111.30	9301 R 0.8	11.60	9301 AL R 0.8	10.2	9302 R 0.8	12.70			
9300 25	25	25	115	35	11	3	123.90	APKT....		APKT....		APKT....				
9300 32	32	32	125	40	11	4	153.30	9301 R 1.2	11.60			9302 R 1.2	12.70			

Bestell-Beispiel: Art.-Nr. 9300 12 = Bestell-Nr. 93001200

Bestell-Beispiel: Art.-Nr. 9301 R0,4 = Bestell-Nr. 9301R040

9310

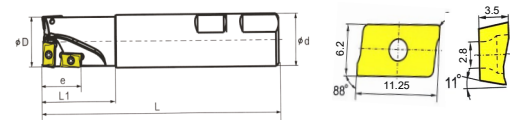

VHM-WP - Bohr-Senkfräser

Zentrumschnitt

Materialeignung ● Sehr Gut ○ Gut	Alu	Alu Guss > 10% Si	Stahl > 750N	Stahl > 900N	Stahl > 1400N	Stahl > 55 HRC	Stahl > 60 HRC	Hochvergütete Stähle	INOX	TITAN / Cu	GG (G)	Universal
9311 TIN		●	●	●	●	○			○	○	○	●
9311 ALU	●	●							○	●	○	●
9312 TIALN		●	●	●	●	●		●	●	●	●	●

VHM-Wendeplatten



TIN-Beschichtet



f. ALU + Kunststoff



TIALN-Beschichtet
für INOX



Art.-Nr.	Abmessungen mm							Wendeplatten	Preis CHF	Art.-Nr.	Preis	Art.-Nr.	Preis	Art.-Nr.	Preis	Schraube	Schlüssel
	φD	φd	L	L1	e	APMT 11	APMT 16										
9310 25	25	25	130	40	20	3	-	205.80	APMT 11		APMT 11		APMT 11		9316-1 M2.5x6.5 CHF 3.40	9318-1 T08 CHF 4.30	
9310 32	32	32	140	50	30	-	3	228.90	9311 R 0.8	11.60	9311 AL R 0.8	10.2	9312 R 0.8	12.70	9316-2 M4x10 CHF 3.40	9318-2 T15 CHF 4.30	
9310 40	40	32	150	60	40	-	4	247.80	APMT 16		APMT 16		APMT 16				
									9313 R 0.8	11.60	9313 AL R 0.8	10.2	9314 R 0.8	12.70			

9320

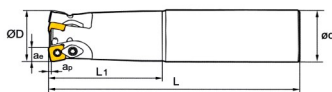

Kopierfräser für extreme Vorschübe VHM-Wendeplatten

Materialeignung ● Sehr Gut ○ Gut	Alu	Alu Guss > 10% Si	Stahl > 750N	Stahl > 900N	Stahl > 1400N	Stahl > 55 HRC	Stahl > 60 HRC	Hochvergütete Stähle	INOX	TITAN / Cu	GG (G)	Universal
9321 TIN	●	●	●	●	●	○			○	○	○	●
9322 TIALN		●	●	●	●	●		●	●	●	●	●

VHM-Wendeplatten



TIN-Beschichtet



TIALN-Beschichtet
für INOX

Art. - Nr.	Abmessungen mm								Preis	Art.- Nr.	Preis	Art.- Nr.	Preis	Schraube	Schraube	Pratze	Schlüssel
	ØD	ap	ae	L1	L	Ød	Zähne										
9320 25	25	1.4	8.8	60	140	25	2	265.70	9321 R1.2	8.80	9322 R1.2	9.90	9325-1 M3.5x08TT CHF4.90	9325-2 M4x8.4 CHF 4.90	9326	9327 T10 CHF 6.90	9328-1 T15 CHF 8.30
9320 323	32	1.4	8.8	70	150	32	3	302.40	9321 R1.2	8.80	9322 R1.2	9.90					
9320 322	32	1.8	11.7	70	150	32	2	349.70	9323 R2.0	9.10	9324 R2.0	10.20	9325-3 M4x8.4 CHF 4.90				9328-2 T15 CHF 8.30
9320 40	40	1.8	11.7	70	150	40	3	505.10	9323 R2.0	9.10	9324 R2.0	10.20					

Bestell-Beispiel: Art.-Nr. 9330 Ø20 = Bestell-Nr. 93302000

VHM-WP - Hochleistungs - Eckfräser

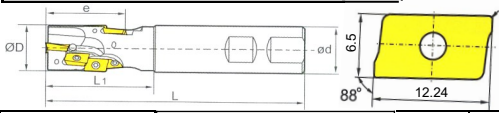
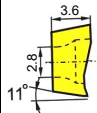
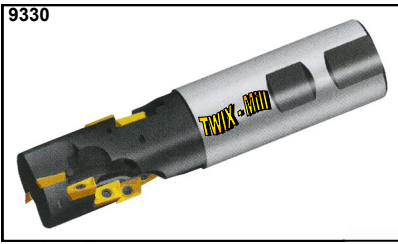

Materialeignung	Alu	Alu Guss > 10% Si	Stahl > 750N	Stahl > 900N	Stahl > 1400N	Stahl > 55 HRC	Stahl > 60 HRC	Hochvergütete Stähle	INOX	TITAN / Cu	GG (G)	Universal
● Sehr Gut ○ Gut												
9331 TIN	●	●	●	●	●	○			○	○	○	●
9331 ALU	●	●							○	●	○	●
9332 TIALN		●	●	●	●	●		●	●	○	●	●



Bestell-Beispiel: Art.-Nr. 9331 R0.4 = 9331R040



Art.-Nr.	Abmessungen mm						Anzahl Wendeplatten	Preis CHF
	φD	φd	L	L1	e	Z		
9330 20	20	20	120	45	29.3	1	3	317.10
9330 25	25	25	130	55	38.9	2	8	351.80
9330 32	32	32	140	65	48.5	2	10	616.40
9330 40	40	40	150	75	58.0	2	14	903.00

Art.-Nr.	Preis	Art.-Nr.	Preis	Art.-Nr.	Preis
APKT....		APKT....		APKT....	
9331 R 0.4	8.80	9331 AL R 0.4	7.60	9332 R 0.4	9.90
9331 R 0.8	8.80	9331 AL R 0.8	7.60	9332 R 0.8	9.90
9331 R 1.2	8.80			9332 R 1.2	9.90

Schraube	Schlüssel
9336 M2.5x6.5 CHF 5.00	9337 T09 CHF 13.

9340

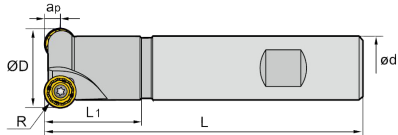

Bestell-Beispiel: Art.-Nr. 9340 Ø25 = Bestell-Nr. 93402500

VHM-WP - Kopier- + Planfräser

Materialeignung	Alu	Alu Guss > 10% Si	Stahl > 750N	Stahl > 900N	Stahl > 1400N	Stahl > 55 HRC	Stahl > 60 HRC	Hochvergütete Stähle	INOX	TITAN / Cu	GG (G)	Universal
● Sehr Gut ○ Gut												
9342 TIN	●	●	●	●	●	●			○	○	○	●
9344 TIALN		●	●	●	●	●		●	●	○	●	●

Bestell-Beispiel: Art.-Nr. 9342 Ø10 = 93421000

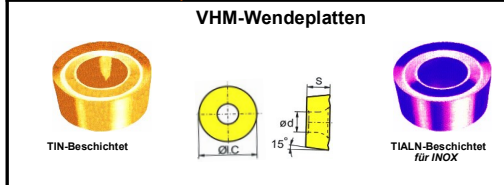

Art.-Nr.	Abmessungen mm					Preis CHF
	φD	φd	L	L1	Z	
9340 25	25	20	100	30	2	123.90
9340 32	32	25	120	35	2	153.30
9340 40	40	32	120	40	3	193.20
9340 50	50	32	120	40	3	228.90

Art.-Nr. RDKW....		φC	S	φ d	Preis CHF	
TIN	TIALN				TIN	TIALN
9342Ø10R5	9344Ø10R5	10	3.97	4.4	7.30	8.30
9342Ø12R6	9344Ø12R6	12	4.73	4.4	7.70	8.70

Schraube	Schlüssel
9346-1 M4 x 8.4 CHF 3.40	
9346-2 M3.5 x 10 CHF 3.40	9348-2 T15 CHF 4.30

VHM-WP - Radius-Kopierfräser

9350

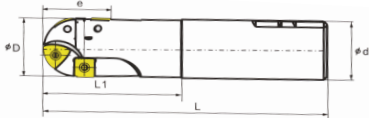

Bestell-Beispiel: Art.-Nr. 9350 Ø20 = Bestell-Nr. 93502000

Materialeignung	Alu	Alu Guss > 10% Si	Stahl > 750N	Stahl > 900N	Stahl > 1400N	Stahl > 55 HRC	Stahl > 60 HRC	Hochvergütete Stähle	INOX	TITAN / Cu	GG (G)	Universal
● Sehr Gut ○ Gut												
9351 TIN	●	●	●	●	●	●			○	○	○	●
9352 TIALN		●	●	●	●	●		●	●	○	●	●

Bestell-Beispiel: Art.-Nr. 9351 R10 = 9351R1000

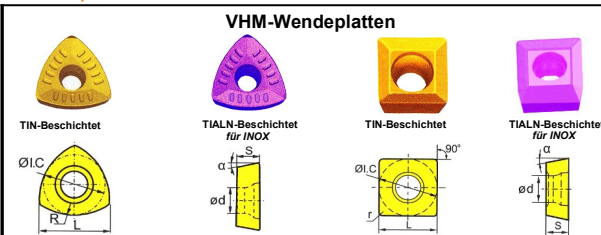

Art.-Nr.	Abmessungen mm					Anzahl Wendeplatten	Preis CHF
	φD	φd	L	e	L1		
9350 20	20	20	125	20	50	2+2	204.80
9350 25	25	25	150	23	70	2+2	268.80
9350 32	32	32	175	31	85	2+2	298.20
9350 40	40	40	175	41	85	2+2	344.40
9350 50	50	40	200	45	100	2+2	415.80

Art.-Nr.	VHM-Wendeschneidplatten								Preis CHF TIN	Preis CHF TIALN
	TIN	TIALN	R	L	IC	S	d	a		
9351R10	9352R10	10	8.4	6.75	2.78	2.8	14°	12.50	13.60	
9351R12.5	9352R12.5	12.5	10.6	8.5	3.18	2.8	14°	13.60	14.60	
9351R16	9352R16	16	13.2	10.5	3.97	4.4	14°	13.90	14.90	
9351R20	9352R20	20	16.1	12.7	4.76	4.4	11°	13.90	14.90	
9351R25	9352R25	25	16.9	12.7	4.76	5.56	11°	13.90	14.90	
9353 R 0.4	9354 R 0.4	0.4	6.35	6.35	3.18	2.8	11°	9.60	10.60	
9353 R 0.8	9354 R 0.8	0.8	12.7	12.7	4.76	4.76	11°	10.90	11.90	

Schraube	Schlüssel	Schlüssel
9356-1 M2.5x5.7 CHF 3.40	9358-1 T07 CHF 4.40	-----
9356-2 M4x8 CHF 3.40	-----	9358-2 T15 CHF 4.40
9356-3 M5x11 CHF 3.40	-----	9358-3 T20 CHF 4.40

9360R

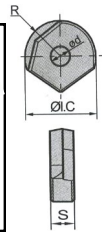
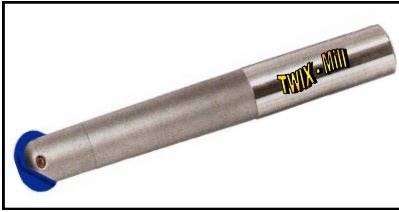

VHM-WP - Kopierfräser

Materialeignung	Alu	Alu Guss > 10% Si	Stahl > 750N	Stahl > 900N	Stahl > 1400N	Stahl > 55 HRC	Stahl > 60 HRC	Hochvergtüete Stähle	INOX	TITAN / Cu	GG (G)	Universal
● Sehr Gut ○ Gut												
9002 TIALN		●	●	●	●	●	●	●	●	○	●	●

Bestell-Beispiel: Art.-Nr. 9360 Ø12 L1=50 =
Bestell-Nr. 9360120050

Art.-Nr.	Abmessungen mm						Preis CHF
	Ø	R	φd	φd1	L1	L	
9360 12 50	12	6	16	11	50	125	282.50
9360 12 70	12	6	16	11	70	150	282.50
9360 16 60	16	8	20	14	60	150	282.50
9360 16 80	16	8	20	14	80	180	282.50
9360 20 75	20	10	25	18	75	180	327.60
9360 20 95	20	10	25	18	95	200	327.60
9360 25 90	25	12.5	32	23	90	200	371.70
9360 25 110	25	12.5	32	23	110	250	371.70
9360 30 110	30	15	40	27	110	250	505.10
9360 30 125	30	15	40	27	125	300	534.50
9360 32 110	32	16	40	29	110	250	594.30
9360 32 125	32	16	40	29	125	300	623.70

VHM-Wendeplatte



TIALN-Beschichtet für INOX

Bestell-Beispiel: Art.-Nr. 9362 R6 = Bestell-Nr. 9362R0600



Art.-Nr.	Preis	Schraube	Schlüssel	
			Art.-Nr.	Preis
APKT....				
9362R6	30.90	9365 -1 M4x10 CHF 6.80	9367 -1 T15 CHF 8.30	-----
9362R8	34.70	9365 -2 M5x12 CHF 6.80		-----
9362R10	39.90	9365 -3 M5x16 CHF 6.80	9367 -2 T20 CHF 16.60	-----
9362R12.5	48.30	9365 -4 M6x20 CHF 25.50		-----
9362R15	58.80	9365 -5 M8x25 CHF 25.50		9367 -3 T30 CHF 48.40
9362R16	62.00			-----

9370/9370W



VHM-WP - Fasenfräser 30° 45° 60°

Materialeignung	Alu	Alu Guss > 10% Si	Stahl > 750N	Stahl > 900N	Stahl > 1400N	Stahl > 55 HRC	Stahl > 60 HRC	Hochvergtüete Stähle	INOX	TITAN / Cu	GG (G)	Universal
● Sehr Gut ○ Gut												
9371 TIN	●	●	●	●	●	○	○	○	○	●	○	●
9372 TIALN	●	○	●	●	●	○	○	○	○	●	○	●

9240/9241

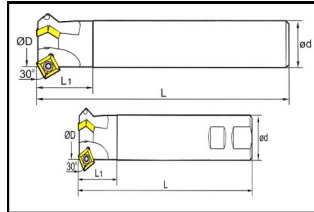

9250/9251

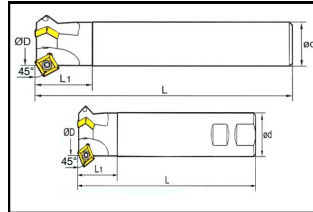

9260/9261

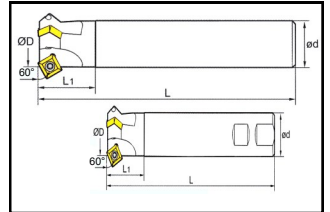

9380/9380W

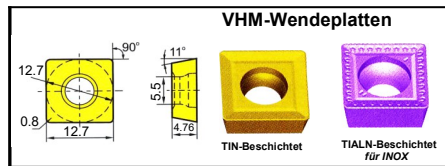
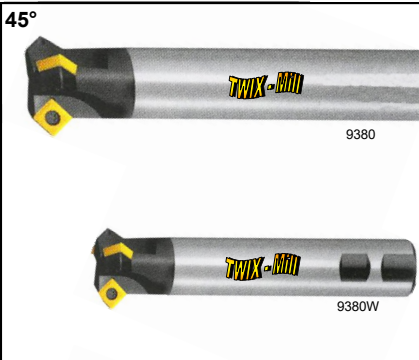

Bestell-Beispiel: Art.-Nr. 9370w Ø12 30°
= Bestell-Nr. 9370w1200

Bestell-Beispiel: Art.-Nr. 9371 R0.8
= Bestell-Nr. 9371R0080

9390/9390W

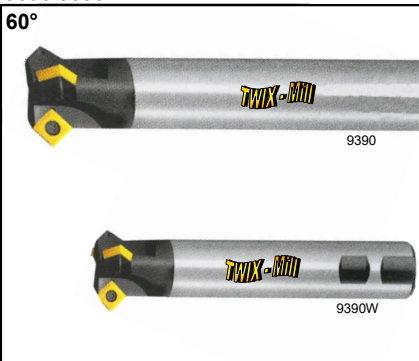

60°

Art.-Nr.	Abmessungen mm						Preis CHF	Art.-Nr.	Preis CHF	Art.-Nr.	Preis CHF	Schraube	Schlüssel		
	φD	φd	L	L1	Z	SPMT..								TIN	SPMT..
9370 12	30°	12	20	100	40	1	138.60	9371 R 0.8	7.90	9372 R 0.8	9.00	9395 M5x11 CHF 5.00	9397 T20 CHF 19.40		
9370 25	30°	25	25	120	40	2	184.80								
9370W 12	30°	12	20	100	40	1	119.70								
9370W 25	30°	25	25	120	40	2	159.60								
9380 12	45°	12	20	100	40	1	138.60								
9380 25	45°	25	25	120	40	2	184.80								
9380W 12	45°	12	20	100	40	1	119.70	9381 R 0.8	7.90	9382 R 0.8	9.00			9395 M5x11 CHF 5.00	9397 T20 CHF 19.40
9380W 25	45°	25	25	120	40	2	159.60								
9390 12	60°	12	20	100	40	1	138.60								
9390 25	60°	25	25	120	40	2	184.80								
9390W 12	60°	12	20	100	40	1	119.70								
9390W 25	60°	25	25	120	40	2	159.60								

9400R



VHM-WP - Planfräser

- universeller Einsatz
- Positive Wendepatten
- Höchste Vorschübe

Materialeignung	Alu	Alu Guss > 10% Si	Stahl > 750N	Stahl > 900N	Stahl > 1400N	Stahl > 55 HRC	Stahl > 60 HRC	Hochvergütete Stähle	INOX	TITAN / Cu	GG (G)	Universal
● Sehr Gut ○ Gut												
9401 TIN		○	●	●	●	●		○	○	○	○	●
9403 TIALN		○	●	●	●	●		●	●	●	●	●

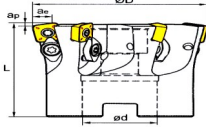

Bestell-Beispiel: Art.-Nr. 9400 Ø50 Z4
= Bestell-Nr. 9400050004

VHM-Wendepatten



TIN-Beschichtet



TIALN-Beschichtet für INOX

Bestell-Beispiel: Art.-Nr. 9401 R1,2
= Bestell-Nr. 9401r0120

Art. - Nr.	Abmessungen mm						Preis	Art.- Nr.	Preis	Art.- Nr.	Preis	Schraube	Schraube	Pratze	Schlüssel	
	ØD	a _p	a _e	L	Ød	Zähne										SDMT....
9400 50 4	50	1.4	8.8	40	22	4	404.30	9401 R 1.2	8.80	9403 R 1.2	9.90	9405-1 M3.5x08TT CHF5.00	9405-2 M4x8.4 CHF 5.00	9406 CHF 5.70	9407-1 T10 CHF6.90	9407-2 T15 CHF 8.30
9400 63 6	63	1.4	8.8	40	22	6	687.80	9402 R 2.0	9.10	9404 R 2.0	10.20	9405-2 M4x8.4 CHF5.00		9407-2 T15 CHF 8.30		
9400 63 5	63	1.8	11.7	40	22	5	538.70									
9400 80 5	80	1.8	11.7	63	27	5	641.60									
9400 100 6	100	1.8	11.7	50	32	6	709.80									

9410



VHM-WP-Hoch - Vorschub - Planfräser

- Universell einsetzbar
- Höchste Vorschübe

Materialeignung	Alu	Alu Guss > 10% Si	Stahl > 750N	Stahl > 900N	Stahl > 1400N	Stahl > 55 HRC	Stahl > 60 HRC	Hochvergütete Stähle	INOX	TITAN / Cu	GG (G)	Universal
● Sehr Gut ○ Gut												
9411 TIN		○	●	●	●	●		○	○	○	○	●
9412 TIALN		○	●	●	●	●		●	●	●	●	●

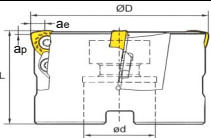

Bestell-Beispiel: Art.-Nr. 9410 Ø63 Z4
= Bestell-Nr. 9410063004

VHM-Wendepatten



TIN-Beschichtet



TIALN-Beschichtet für INOX

Bestell-Beispiel: Art.-Nr. 9411 R1,5
= Bestell-Nr. 9411r0150

Art. - Nr.	Abmessungen mm						Preis	Art.- Nr.	Preis	Art.- Nr.	Preis	Schraube	Pratze	Schlüssel
	ØD	a _p	a _e	L	Ød	Zähne								
9410 63 4	63	1.5	5.66	50	22	4	659.40	9411 R 1.5	11.30	9412 R 1.5	12.40	9414 M5x13 CHF5.00	9416 CHF 5.70	9418 T20 CHF 44.30
9410 80 5	80	1.5	5.66	63	27	5	687.80							
9410 125 7	125	1.5	5.66	63	40	7	827.40							

9420

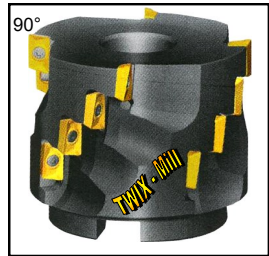

VHM-WP - Walzenstirfräser Eckfräser 90°

Materialeignung	Alu	Alu Guss > 10% Si	Stahl > 750N	Stahl > 900N	Stahl > 1400N	Stahl > 55 HRC	Stahl > 60 HRC	Hochvergütete Stähle	INOX	TITAN / Cu	GG (G)	Universal
● Sehr Gut ○ Gut												
9421 TIN		○	●	●	●	●		○	○	○	○	●
9421 ALU	○	●	○	○	○	○		○	○	○	○	○
9422 TIALN		○	●	●	●	●		●	●	●	●	●

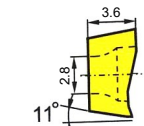
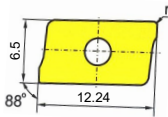

Bestell-Beispiel: Art.-Nr. 9420 Ø50 Z4
= Bestell-Nr. 9420050004

VHM-Wendepatten



TIN-Beschichtet



f. ALU + Kunststoff



TIALN-Beschichtet für INOX

- universeller Einsatz
- Positive Wendepatten
- Höchste Vorschübe

Bestell-Beispiel: Art.-Nr. 9421 R0,4
= Bestell-Nr. 9421r0040

Art.-Nr.	Abmessungen mm						Anzahl Wendepatten	Preis CHF	Art.-Nr.	Preis	Art.-Nr.	Preis	Art.-Nr.	Preis	Schraube	Schlüssel
	φD	φd	L	e	Z	APKT....										
9420 50 4	50	22	58	39	4	16	682.50	9421 R 0.4	8.80	9421 AL R 0.4	7.70	9422 R 0.4	9.90	9 425 M2.5x6.5 CHF 5.00	9427 T09 CHF 13.90	
9420 63 4	63	27	58	39	4	16	744.50	9421 R 0.8	8.80	9421 AL R 0.8	7.70	9422 R 0.8	9.90			
9420 80 5	80	32	63	39	5	20	936.60	9421 R 1.2	8.80	9421 AL R 1.2	7.70	9422 R 1.2	9.90			
9420 100 6	100	40	63	39	6	24	1'064.70									



Bestell-Beispiel: Art.-Nr. 9430 Ø50 = Bestell-Nr. 943005000

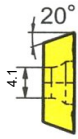
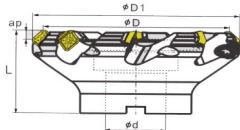
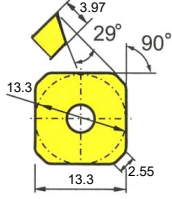
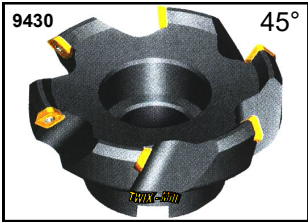

VHM-WP - Planfräser 45°

Materialeignung	Alu	Alu Guss > 10% Si	Stahl > 750N	Stahl > 900N	Stahl > 1400N	Stahl > 55 HRC	Stahl > 60 HRC	Hochvergütete Stähle	INOX	TITAN / Cu	GG (G)	Universal
● Sehr Gut ○ Gut												
9431 TIN		○	●	●	●	●		○	○	○	○	●
9431 ALU	○	●	○						●	●		○
9432 TIALN		○	●	●	●	●		●	●	●	●	●



Bestell-Beispiel: Art.-Nr. 9431 R0.8 = Bestell-Nr. 9431r0080



Art.-Nr.	Abmessungen mm						Preis CHF
	φ D	φ D1	φ d	L	ap	Z	
9430 50	50	61	22	40	6	3	186.90
9430 63	63	74	22	40	6	4	204.80
9430 80	80	91	27	50	6	4	245.70
9430 100	100	107	32	50	6	5	300.30
9430 125	125	131	40	63	6	6	373.80

Art.-Nr.	Preis CHF TIN	Art.-Nr.	Preis CHF ALU	Art.-Nr.	Preis CHF TIALN	Schraube	Schlüssel
SEET		SEET		SEET			
9431 R 0.8	15.10	9431 AL R 0.8	9.60	9432R 0.8	16.20	9435-1 M3.5x10 CHF 5.10	9435-2 T15 CHF 13.90

Bestell-Beispiel: Art.-Nr. 9440 Ø50 = Bestell-Nr. 944005000

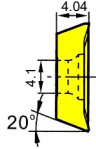
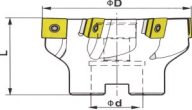
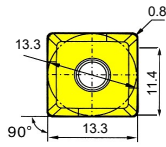

Messerköpfe VHM-WP - Planfräser



Materialeignung	Alu	Alu Guss > 10% Si	Stahl > 750N	Stahl > 900N	Stahl > 1400N	Stahl > 55 HRC	Stahl > 60 HRC	Hochvergütete Stähle	INOX	TITAN / Cu	GG (G)	Universal
● Sehr Gut ○ Gut												
9441 TIN		○	●	●	●	●		○	○	○	○	●
9441 ALU	○	●	○						●	●		○
9442 TIALN		○	●	●	●	●		●	●	●	●	●



Bestell-Beispiel: Art.-Nr. 9441 R0.8 = Bestell-Nr. 9441r0080

Art.-Nr.	Abmessungen mm						Preis CHF
	D	φ d	φ L	apmax	Z		
9440 50	50	22	40	10.8	5	256.20	
9440 63	63	22	40	10.8	6	308.70	
9440 80	80	27	50	10.8	8	337.10	
9440 100	100	32	50	10.8	10	393.80	
9440 125	125	40	63	10.8	12	507.20	

Art.-Nr.	Preis CHF TIN	Art.-Nr.	Preis CHF ALU	Art.-Nr.	Preis CHF TIALN
SEET		SEET		SEET	
9441 R 0.8	8.60	9441 AL R 0.8	8.10	9442 R 0.8	9.70

Schraube	Unterlage	Zwischen schraube	Schlüssel	Schlüssel
9446 M3.5x12 CHF 5.00	9447 CHF 5.70	9448 M5x7 CHF 7.80	9449-1 T15 CHF 13.90	9449-2 H35 CHF 3.90

Bestell-Beispiel: Art.-Nr. 9450 Ø63 B4 = Bestell-Nr. 9450063004

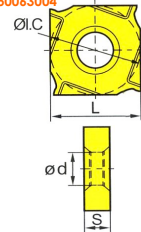

VHM-WP - Scheibenfräser / Schlitzfräser

• Universal einsetzbar



Materialeignung	Alu	Alu Guss > 10% Si	Stahl > 750N	Stahl > 900N	Stahl > 1400N	Stahl > 55 HRC	Stahl > 60 HRC	Hochvergütete Stähle	INOX	TITAN / Cu	GG (G)	Universal
● Sehr Gut ○ Gut												
9452 TIALN	○	●	●	●	●	●		●	●	○	●	●

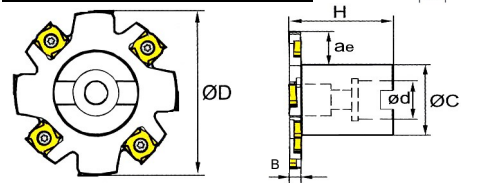

Art.-Nr.	Abmessungen mm							Preis CHF
	φ D	φ d	φ c	H	B	ae max	Z	
9450 634	63	22	32	50	4	10	6	632.10
9450 804	80	22	40	50	4	18	8	837.90
9450 1004	100	27	48	50	4	23	10	823.2
9450 635	63	22	32	50	5	10	6	632.10
9450 805	80	22	40	50	5	18	8	837.90
9450 1005	100	27	48	50	5	23	10	961.80
9450 636	63	22	32	50	6	10	6	632.10
9450 806	80	22	40	50	6	18	8	837.90
9450 1006	100	27	48	50	6	23	10	961.80
9450 1256	125	40	70	50	6	24	12	1'261.10
9450 1606	160	40	70	50	6	41	16	1'570.80

Art.-Nr.	Preis CHF TIALN	Schraube	Schlüssel
Bestell-Beispiel: Art.-Nr. 9452 2.3 = Bestell-Nr. 94520230			
9452 2.3	15.40	9455-1 M4x3.3 CHF 8.60	9457 T10 CHF 18.10
9452 3.0	15.70	9455-2 M4x4.3 CHF 8.60	
9452 3.5	16.70	9455-3 M4x5.3 CHF 8.60	



9460

VHM-WP-Tangential - Hochleistungs - Fräser 60°



60°

Materialeignung	Alu	Alu Guss > 10% Si	Stahl > 750N	Stahl > 900N	Stahl > 1400N	Stahl > 55 HRC	Stahl > 60 HRC	Hochvergütete Stähle	INOX	TITAN / Cu	GG (G)	Universal
● Sehr Gut ○ Gut		○	●	●	●	●	●	●	○	○	●	●
9461 TIN		○	●	●	●	●	●	●	○	○	●	●
9462 TIALN			●	●	●	●	●	●	●	●	●	●

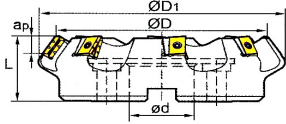

Bestell-Beispiel: Art.-Nr. 9460 160
= Bestell-Nr. 946016000

VHM-Wendeplatten



TIN-Beschichtet



TIALN-Beschichtet für INOX

Bestell-Beispiel: Art.-Nr. 9461 9.525
= Bestell-Nr. 94610952

Art. - Nr.	Abmessungen mm						Preis	Art.- Nr.	Preis	Art.- Nr.	Preis	Schraube	Unterlage	Unterlagen Schraube	Schlüssel	
	ØD	ØD1	Ød	L	apmax	Zähne									LNKT....	LNKT....
9460 160	160	189	40	63	17	6	1'473.20	9461 9.525	22.30	9462 9.525	23.30	9465 M5x17 CHF 5.00	9466 CHF 40.00	9467 M3.5x15 CHF 5.00	9468 T20 CHF 18.10	9469 T15 CHF 5.70
9460 200	200	229	60	70	17	8	1'546.-									

9470

VHM-WP-Tangential - Hochleistungs - Fräser 75°

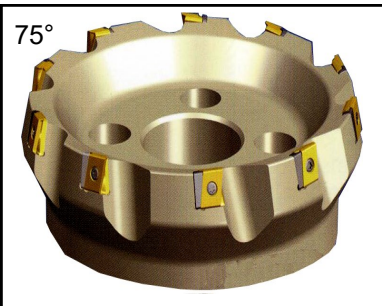

75°

Materialeignung	Alu	Alu Guss > 10% Si	Stahl > 750N	Stahl > 900N	Stahl > 1400N	Stahl > 55 HRC	Stahl > 60 HRC	Hochvergütete Stähle	INOX	TITAN / Cu	GG (G)	Universal
● Sehr Gut ○ Gut		○	●	●	●	●	●	●	○	○	●	●
9471 TIN		○	●	●	●	●	●	●	○	○	●	●
9472 TIALN			●	●	●	●	●	●	●	●	●	●

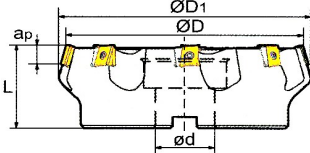

Bestell-Beispiel: Art.-Nr. 9470 160
= Bestell-Nr. 947016000

VHM-Wendeplatten



TIN-Beschichtet



TIALN-Beschichtet für INOX

Bestell-Beispiel: Art.-Nr. 9471 6.35
= Bestell-Nr. 94710635

Art. - Nr.	Abmessungen mm						Preis	Art.- Nr.	Preis	Art.- Nr.	Preis	Schraube	Unterlage	Unterlagen Schraube	Schlüssel	
	ØD	ØD1	Ød	L	apmax	Zähne									LNKT....	LNKT....
9470 160	160	170	40	63	8	8	1037.40	9471 6.35	16.90	9472 6.35	17.60	9475 M3x17 CHF 5.00	9476 CHF 20.00	9477 M4x15 CHF 5.00	9478 T10 CHF 18.10	9479 T15 CHF 5.70
9470 200	200	208	60	70	8	10	1'248.50									

9480

VHM-WP-Tangential - Hochleistungs - Fräser 89°

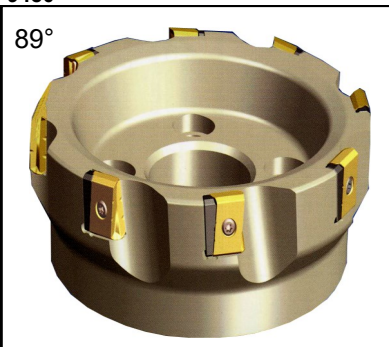

89°

Materialeignung	Alu	Alu Guss > 10% Si	Stahl > 750N	Stahl > 900N	Stahl > 1400N	Stahl > 55 HRC	Stahl > 60 HRC	Hochvergütete Stähle	INOX	TITAN / Cu	GG (G)	Universal
● Sehr Gut ○ Gut		○	●	●	●	●	●	●	○	○	●	●
9481 TIN		○	●	●	●	●	●	●	○	○	●	●
9482 TIALN			●	●	●	●	●	●	●	●	●	●

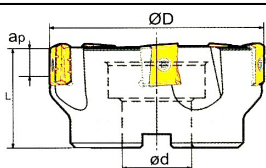

Bestell-Beispiel: Art.-Nr. 9480 160
= Bestell-Nr. 948016000

VHM-Wendeplatten



TIN-Beschichtet



TIALN-Beschichtet für INOX

Bestell-Beispiel: Art.-Nr. 9481 6.35
= Bestell-Nr. 94810635

Art. - Nr.	Abmessungen mm					Preis	Art.- Nr.	Preis	Art.- Nr.	Preis	Schraube	Unterlage	Unterlagen Schraube	Schlüssel	
	ØD	Ød	L	apmax	Zähne									LNKT....	LNKT....
9480 160	160	40	63	8	8	942.90	9481 6.35	16.60	9482 6.35	17.60	9485 M3x17 CHF 5.00	9486 CHF 21.20	9487 M4x15 CHF 5.00	9488 T10 CHF 18.10	9489 T15 CHF 5.70
9480 200	200	60	70	8	10	1'248.50									

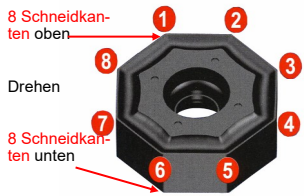

NEU mit 16 Schneidkanten

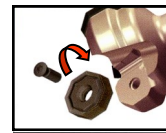

8 Schneiden 8 Schneiden
= 16 Schneidkanten



VHM-WP - Schaftfräser 45°

- **Höchste Produktivität**
- **Unerreichte Preisleistung durch 16 Schneiden**
- **Doppelte Schneidenanzahl gegenüber Konkurrenz Produkten**
- **Positive Schnittgeometrie**
- **Höchste Schnittgeschwindigkeit**
- **Höchste Vorschübe**
- **Kleinste Preise**
- **Universell im Einsatz**

9490

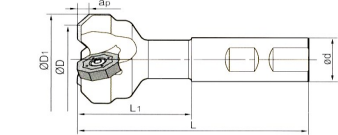
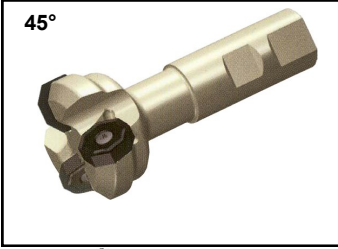

Bestell-Beispiel: Art.-Nr. 9490 Ø32 = Bestell-Nr. 94903200

Materialeignung	Alu	Alu Guss > 10% Si	Stahl > 750N	Stahl > 900N	Stahl > 1400N	Stahl > 55 HRC	Stahl > 60 HRC	Hochvergütete Stähle	INOX	TITAN / Cu	GG (G)	Universal
● Sehr Gut ○ Gut	●	●	●	●	●	●	●	●	●	○	●	●

VHM-Wendeplatten

TIALN-Beschichtet für INOX

Bestell-Beispiel: Art.-Nr. 9491 R 0.83 = Bestell-Nr. 9491r0083

Art. - Nr.	Abmessungen mm							Preis CHF	Art.-Nr.	Preis	Schraube	Schlüssel
	ØD	ØD1	ød	L	L1	apmax	Zähne Z					
9490 32	32	47	25	111	55	5	2	185.90	9491 R 0.83	18.60	9493 M5 x 13 CHF 5.00	9494 T 20 CHF 44.30
9490 40	40	55	25	111	55	5	3	260.40				
9490 50	50	65	25	111	55	5	4	309.80				



NEU mit 16 Schneidkanten

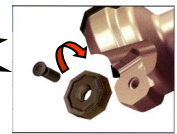
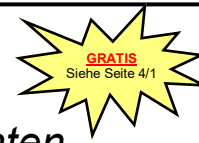

8 Schneiden 8 Schneiden
= 16 Schneidkanten

VHM-WP - Planfräser 45°

- **Höchste Produktivität**
- **Unerreichte Preisleistung durch 16 Schneiden**
- **Doppelte Schneidenanzahl gegenüber Konkurrenz Produkten**
- **Positive Schnittgeometrie**
- **Höchste Schnittgeschwindigkeit**
- **Höchste Vorschübe**
- **Kleinste Preise**
- **Universell im Einsatz**

9495

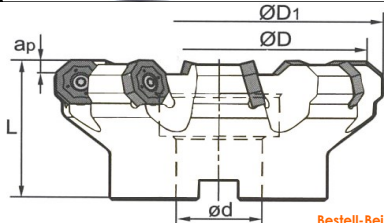

Bestell-Beispiel: Art.-Nr. 9495 Ø63 = Bestell-Nr. 949506300

Materialeignung	Alu	Alu Guss > 10% Si	Stahl > 750N	Stahl > 900N	Stahl > 1400N	Stahl > 55 HRC	Stahl > 60 HRC	Hochvergütete Stähle	INOX	TITAN / Cu	GG (G)	Universal
● Sehr Gut ○ Gut	●	●	●	●	●	●	●	●	●	○	●	●

VHM-Wendeplatten

TIALN-Beschichtet für INOX

Bestell-Beispiel: Art.-Nr. 9496 R 0.83 = Bestell-Nr. 9496r0083

Art. - Nr.	Abmessungen mm							Preis CHF	Art.-Nr.	Preis	Schraube	Schlüssel
	ØD	ØD1	ød	L	apmax	Zähne Z						
9495 63	63	78	22	40	5	5	408.50	9496 R 0.83	18.60	9498 M5 x 13 CHF 5.00	9499 T 20 CHF 44.30	
9495 80	80	95	27	50	5	6	459.90					
9495 100	100	115	32	63	5	7	510.30					
9495 125	125	140	40	63	5	8	610.10					
9495 160	160	175	40	63	5	10	730.80					